

READ ALL INSTRUCTIONS COMPLETELY AND THOROUGHLY UNDERSTAND THEM BEFORE DOING ANYTHING.
CALL CHASSISWORKS TECH SUPPORT (916) 388-0288 IF YOU NEED ASSISTANCE.

INSTALLATION GUIDE



PKG A-ARM

A-Arm Suspension for Chassisworks 4x2" Crossmember



Description: A-Arm Suspension and Steering System for Chassisworks 4x2" crossmembers and front clips, including 4x2" weld-in crossmember and front clips, and bolt-in front clips. Includes: bare steel or black powder coated control arms, balljoints with wrench, bare or black powder coated sculpted spindles, OEM-style or bump-steer adjustable tie rods, billet manual rack and pinion (satin or polished) or power rack and pinion (black or chrome for 30" or 33" crossmembers; right- and left-hand-drive versions available), shock simulator tools. Optional single- or double-adjustable VariShock coil-overs with springs, anti-roll bar with poly or heim-joint endlinks, vented-rotor disc brake kit (11-3/4", 13", or 14").

INSTALLATION GUIDE

CHASSISWORKS Street Machine A-Arms



3 *Equipment List and
Torque Specifications*

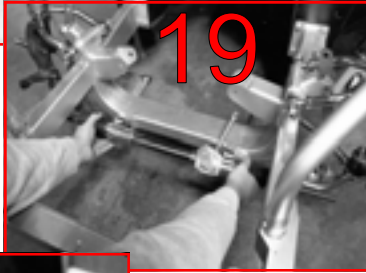

5 *Installing Lower & Upper
A-arms, and Spindles*

19 *Installing Steering Rack*

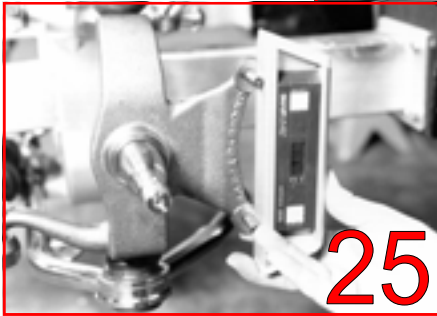

25 *Front Suspension Alignment*

32 *Installing Antiroll Bar*

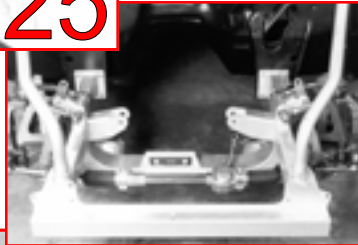

38 *Installing Shocks and Springs*

42 *Installing Brakes*

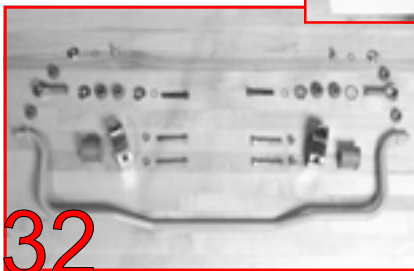

55 *Selecting an A-Arm Crossmember*

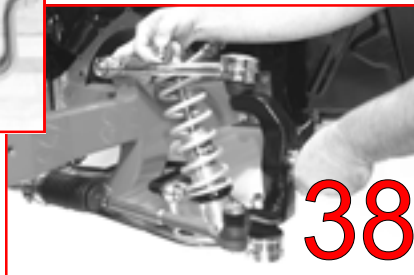

8661 Younger Creek Drive, Sacramento, CA 95828 Telephone (916) 388-0288

#91A-ARM

Revision Date 06/20/03

Copyright 2003

CONGRATULATIONS

You have purchased the finest front suspension crossmember available. We hope you are as excited about installing it as we were about designing it.

This assembly booklet should guide you through a seamless installation. However, if you have any questions please give our tech line a call at (916) 388-0288. Monday through Friday 7:00 a.m. to 5:00 p.m., Saturday 8:00 a.m. to 1:00 p.m. PST.

Every effort has been made to insure that each component has been boxed correctly. However, we urge you to open each box and verify it's contents against the enclosed parts list.

We also suggest that you read this entire assembly booklet before you begin. This will help you become familiar with the project.

Please remember that when you modify a vehicle, you assume all risks. You are changing the structural integrity manufactured into the original vehicle. As such, you need to be cognizant of potential failures. Initially you must conduct a series of short tests in a safe location. Test for handling, steering, and braking at slightly increasing speeds.

Once you are confident the vehicle handles and stops properly, take a series of drives with slightly increasing speeds stopping to check all components. Gradually increase the distance of your drives. Once you have confirmed your installation is road-worthy, you must develop a maintenance program. You must check all components for looseness, and wear and tear on a regular schedule. Your schedule must be more intense and frequent than a regular OEM vehicle.

Chris Alston's Chassisworks would appreciate any feedback regarding your experience during installation and use of this frame.

That said, let's install!

Recommended Equipment List

This list will give you a good idea of the necessary tools required to complete this installation. There will be additional items needed.

Hand Tools

- ◆ Adjustable wrench
- ◆ Allen wrench set
- ◆ Anti-seize compound
- ◆ Brakeline wrench
- ◆ Center punch
- ◆ Combination wrenches 3/8 to 3/4"
- ◆ Drill bit size #21(.159)
- ◆ Level
- ◆ Loctite #242 thread lock
- ◆ Socket set 3/8 to 3/4" with 3/8 drive
- ◆ Steel & plastic head hammers
- ◆ Straight blade screwdriver
- ◆ Tape measure
- ◆ Tap handle small and medium
- ◆ Tap sizes: 10-32, 3/8-16, 1/2-13, 5/8-18

Shop Equipment

- ◆ Digital level
- ◆ 3/8" electric drill

Torque Specification Chart

<i>DESCRIPTION</i>	<i>TORQUE</i>	<i>DESCRIPTION</i>	<i>TORQUE</i>
A-arm pivot studs	60 lb-ft	Motor mount spuds	20 lb-ft
Antiroll bar clamp socket head allens 3/8-16 x 2 1/2"	20 lb-ft	Rack clamp socket head allens 1/2-13 x 2"	45 lb-ft
Antiroll bar link eyebolt button head allen 3/8-16 x 3/4"	20 lb-ft	Rack clamp caps socket head allens 5/16-18 x 1"	15 lb-ft
Antiroll bar link eyebolt socket head allen 3/8-16 x 2 1/4"	20 lb-ft	Shock spuds	20 lb-ft
Balljoints	150 lb-ft	Shock bolts 1/2-20 x 2 1/2"	45 lb-ft
Balljoint studs	105 lb-ft	Tie rod stud	60 lb-ft
Caliper socket head allens 3/8-16 x 1 3/8"	30 lb-ft	Wheel studs 1/2-20 x 2 1/4" 12 point	40 lb-ft
		We recommend applying a small amount of Loctite™ on all fasteners except the balljoint studs, and the tie rod studs.	

DISCLAIMER OF WARRANTY

Purchasers recognize and understand that products and services manufactured, provided, and/or sold by CHRIS ALSTON'S CHASSISWORKS, INC., are exposed to many varied conditions due to the manner in which they are used. Purchasers assume the responsibility to develop a Maintenance Procedure to identify and replace worn components before they fail. Your Maintenance Procedure must include every component on the vehicle. CHRIS ALSTON'S CHASSISWORKS, INC., makes no claims or guarantees that any product or service is designed or intended to comply with any industry standards or government regulations. CHRIS ALSTON'S CHASSISWORKS, INC., makes no claims or guarantees in reference to any acceptance for use of its products or services by any entity or racing association, or that its products can legally be installed on any vehicle that operates on a public highway.

CHRIS ALSTON'S CHASSISWORKS, INC., reserves the right to make changes or improvements in design, materials or specifications or make product changes without incurring any obligation to replace, change or improve products manufactured prior hereto.

There are NO WARRANTIES, either expressed or implied. There is no warranty of merchantability. Neither the seller nor manufacturer will be liable for ANY loss, damage or injury either direct or indirect, arising from the use or inability to determine the appropriate use of any product. Buyer will not rely on CHASSISWORKS skill or judgment to select or furnish the proper part or equipment for their application. Buyer expressly affirms that they are relying upon their own skill and judgment to select and purchase suitable goods.

Before any attempt at installation, all drawings and/or instruction sheets must be completely reviewed to determine the suitability of the product for its intended use and that the buyer has the skills required to install and maintain the product. Buyer assumes all responsibility and risk for correct installation. CHRIS ALSTON'S CHASSISWORKS, INC., accepts no responsibility for failure to read, or understand the installation guidelines. All products are intended for racing or off-road use and may not be legal for highway use. The information contained in this *Installation Guide* is correct to the best of our knowledge and belief, having been compiled from reliable sources. However, CHRIS ALSTON'S CHASSISWORKS, INC., can not assume responsibility for possible error. BUYER IS RESPONSIBLE FOR DETERMINING THE SUITABILITY OF ANY AND ALL PRODUCTS PURCHASED FROM CHRIS ALSTON'S CHASSISWORKS, INC.

It is expressly understood and agreed between purchasers and Chris Alston's Chassisworks, Inc., that as part of the bargain between CHRIS ALSTON'S CHASSISWORKS, INC., and purchasers, and in consideration of doing business with each other, all purchasers take, select and purchase said racing parts, equipment any and all inventory, or services from CHRIS ALSTON'S CHASSISWORKS, INC., "as is" and "with all faults" and CHRIS ALSTON'S CHASSISWORKS, INC., shall always provide purchasers with a full and complete opportunity to examine, at purchasers' leisure and convenience, any racing parts and equipment, any and all inventory, or services when purchasing or contemplating purchasing from CHRIS ALSTON'S CHASSISWORKS, INC. Use of CHRIS ALSTON'S CHASSISWORKS, INC., products constitutes acceptance of this agreement in its entirety.

BUYER IS RESPONSIBLE FOR DETERMINING THE SUITABILITY OF ANY AND ALL PRODUCTS PURCHASED FROM CHRIS ALSTON'S CHASSISWORKS, INC. NO PART, COMPONENT, INVENTORY, OR SERVICE MANUFACTURED OR SOLD BY CHRIS ALSTON'S CHASSISWORKS, INC., IS DESIGNED OR INTENDED TO PREVENT INJURY OR DEATH.

Purchasers understand and agree that no officer, director, employee, salesperson, or agent of CHRIS ALSTON'S CHASSISWORKS, INC., has any authority to make any statement contrary to the terms of this agreement. CHRIS ALSTON'S CHASSISWORKS, INC., disavows any statement contrary to what is herein above written.

This installation guide shows the front suspension being installed on our Chevy II Bolt-On Clip. The installation procedure is the same for the Street Machine Crossmember you purchased. If you have not purchased the Crossmember go to page 55, for help selecting the correct one for your application.

Installing Suspension

In this section you will install all of the front suspension components and align the front end geometry.

If you purchased plain steel A-arms, have them painted or powder coated before you assemble them. Do not get paint in the balljoint housing thread bore or in the pivot bushing bores. The balljoint bores are precision machined. Consequently, you can not install and remove the balljoints multiple times. The self-locking threads on the balljoint will destroy the balljoint housing if it is removed and installed several times. Have your A-arms painted before the balljoint is assembled to minimize this potential problem.

Do not plate or chrome the A-arms. The plating solution can leak into the tubes and cause them to rust from the inside out. If you drill drain holes in the tubes, the A-arm will crack from the holes. If you want a highly polished look, purchase our stainless A-arms.

The mild steel lower A-arms are shipped without their pivot bushings installed to make painting or powder coating easier. Use an arbor press to install the bushings.



Installing Lower & Upper A-arms, and Spindles

The first parts installed will be the upper and lower A-arms. The stainless steel lower A-arm comes with all of the bushings installed. You will be installing the bushings and rod ends in the upper A-arms later.



For identification, the driver side A-arm assembly is embossed with a “D” on the balljoint housing. The passenger side is embossed with a “P” on the balljoint housing.



The balljoint rubber boot is installed in the balljoint housing first. Because the boot fits tight in the housing, installing it before the balljoint is easier. Drop the boot into the machined bore in the balljoint housing.



Work your way around the boot's edge, pushing it down into the bore with your fingers. You can also use a blunt tool to do this.



During the assembly process we are going to coat all of the threaded assemblies with an anti-seize compound to prevent the threads from being damaged and aid disassembly in the future.

Put a thin layer of anti-seize on the balljoint threads.



The balljoint is then screwed into the balljoint housing as far as possible by hand. Make absolutely sure that the thread starts straight. This is a little tricky. The threads on the balljoint are easy to cross thread.



Use the balljoint wrench included with your kit to tighten the balljoint. Tighten it until it is fully seated against the balljoint housing. The force required can be over 150 lb-ft of torque. Be careful not to scratch the A-arms. Repeat this for the passenger side lower A-arm.

One convenient method for holding the A-arm while installing the balljoint is to temporarily install the A-arm on the frame.



The upper A-arms will be assembled next. Although they are very similar, they are not identical. The letter “D” or “P” on the balljoint housing identifies which side of the car the A-arm installs in.



Use a 5/8-18 tap to chase the threads in the upper A-arm. Clear any debris left in the threads.



Use the same procedure to assemble the upper A-arm as the lower. First, install the balljoint boot into the balljoint housing.



Next, apply a layer of anti-seize to the balljoint threads.



Thread the balljoint in as far as possible by hand.



Finish tightening the balljoint with the balljoint wrench until it is seated tight against the balljoint housing. Repeat this for the passenger side upper A-arm.



Install the rod ends into the upper A-arms. To provide an initial alignment baseline, the jam nut should be threaded until there is 1-1/16 inches of thread remaining past the jam nut.



After the application of another dab of anti-seize, the rod ends are threaded into the A-arms, until the jam nuts are snug against the arm itself.

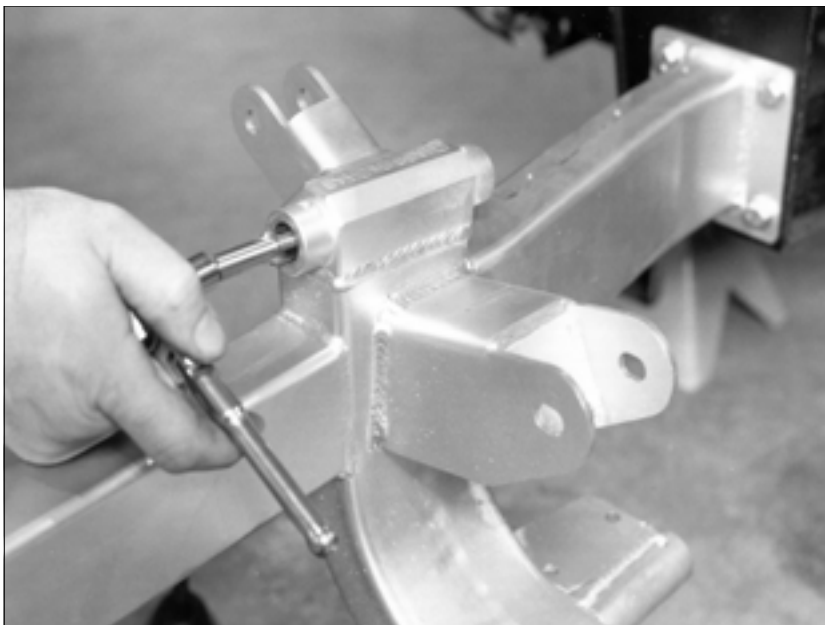

This step must be done carefully because the upper and lower A-arm mounts are threaded and welded to the frame. Use the 5/8-18 tap to chase the threads on the front and back sides of both upper mounts. Blow any remaining particles out of the hole with an air hose.



Next, chase the threads in the lower A-arm mounts with the 5/8-18 tap and blow-out any remaining particles.



Now, apply some anti-seize to the threads of the pivot stud. Also put anti-seize inside the bore of the A-arm mounts. Insert one of the lower A-arm pivot studs and then run it in all the way to its stop, it should go in easy. Use the same procedure to verify all of the pivot studs will easily thread into their mounting locations.



The lower A-arm fits tight over the mount. Slide the rear of the A-arm onto the mount and then use a piece of wood between the frame and the A-arm to pry it over the mount.

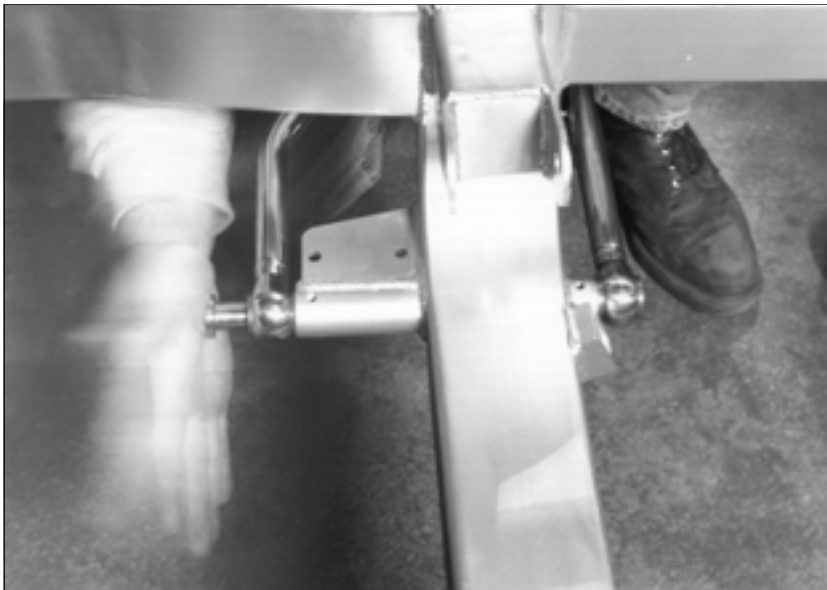

When installing the lower A-arm pivot studs, be careful not to damage the threads. Tap the pivot stud into place with your hand.



If the hand method does not work, you can use a plastic-tipped hammer to gently install the pivot stud. It is best to move the pivot stud a small amount at a time until the threads make contact.

Do not put grease on the pivot bushings they are self-lubricating.



Once the pivot studs are in place, use an Allen T-wrench to tighten them. The pivot studs should go in easily and should be tightened until they are fully seated. This will give the bushings the proper amount of crush, and allow the lower A-arm to move with a small amount of resistance.



If you have to remove the lower A-arm pivot studs, use a piece of wood and a few taps with a hammer while turning the pivot stud counter-clockwise. The pivot stud will come out easily.



After tightening the lower A-arm pivot studs, check to be sure the A-arm swings freely but snugly throughout its travel.



The lower A-arm should also stay suspended when released. It should take a few pounds of pressure to make it move.



A set screw is used to lock the A-arm pivot studs. The set screw locks on the groove machined into the pivot stud.



Before installing the pivot stud set screws, apply a drop of Loctite™ thread sealing compound to the screws. Be careful not to get excess Loctite™ in the pivot stud bore.

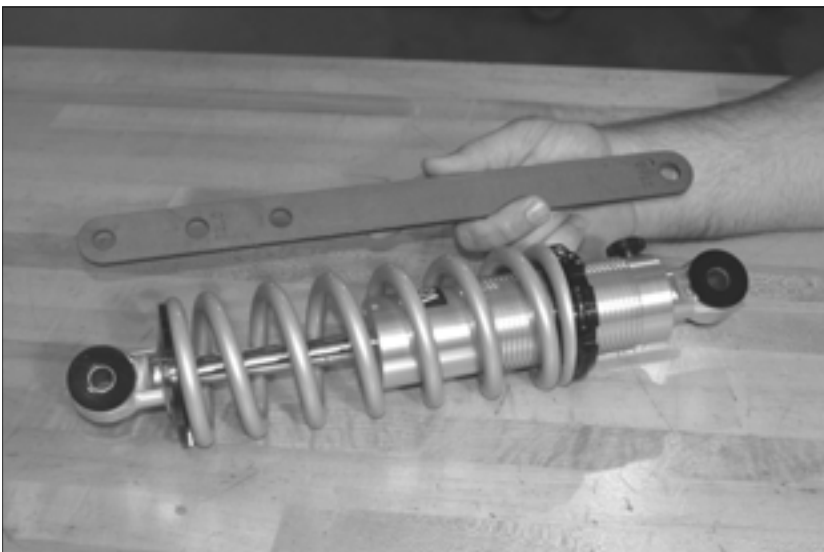

The next step is to install the upper A-arm and spindle. During this step you are going to need the lower A-arm at its ride height position.

Two of these shock simulators are included in the suspension kit. The top hole represents full shock extension, the bottom hole full compression, and the middle hole (at 12 inches) represents the ride height of the shock absorber.



Next, install the shock simulator at the ride height position. Install the lower bolt first and then the upper.



Installing the upper A-arm is similar to installing the lower A-arm. Slide the front rod end over the front mount first and then swivel the rear one into place.



Install the upper mount bolts just like the lower mount bolts. Do not fully tighten them now because they need to be moved when we adjust the front suspension settings later. Repeat the installation of the upper A-arm on the passenger side.



You are now going to install the dropped spindles. The "L" cast into the back of the spindles, does not designate "Left," it is the foundry mark. The best way to identify the driver and passenger side spindle, is to remember the steering arm (shown with arrow) always goes toward the front of the car.



Place the driver side spindle over the balljoint and thread the 9/16-18 castle nut on.



The balljoint castle nut will not thread on easily if the threads are nicked. A thread file can be used to correct the problem. After filing, try the castle nut again before putting the spindle on. Thread files can be found at most auto parts stores.



Place the spindle over the lower balljoint and install the washer and castle nut. The upper A-arm is then lowered into position and secured to the spindle with another washer and castle nut.



Tightened both upper and lower balljoint castle nuts.



Insert the cotter pin through the hole in the balljoint. You may need to tightened it a small amount until the slots in the castle nut align with the hole.



With the cotter pin installed, use pliers to fold the legs over the castle nut. One leg goes down the other over the top of the balljoint stud.



Repeat the procedure for the upper A-arm. First tightening the castle nut.



Install the cotter pin and fold the legs over as we did on the lower one. Repeat this procedure on the passenger side of the car.

Installing Steering Rack

Mounting the steering rack is next. Chase the threads in the rack mounting bosses with a 1/2-13 tap before mounting the billet mounts.



The rack mounting bosses are factory welded to the frame. Use the 1/2-13 x 2" socket head allen and custom 1/2" lock washer to mount the lower half of the billet rack clamp to the mounting boss. Use a small amount of Loctite™ on the socket head allen.

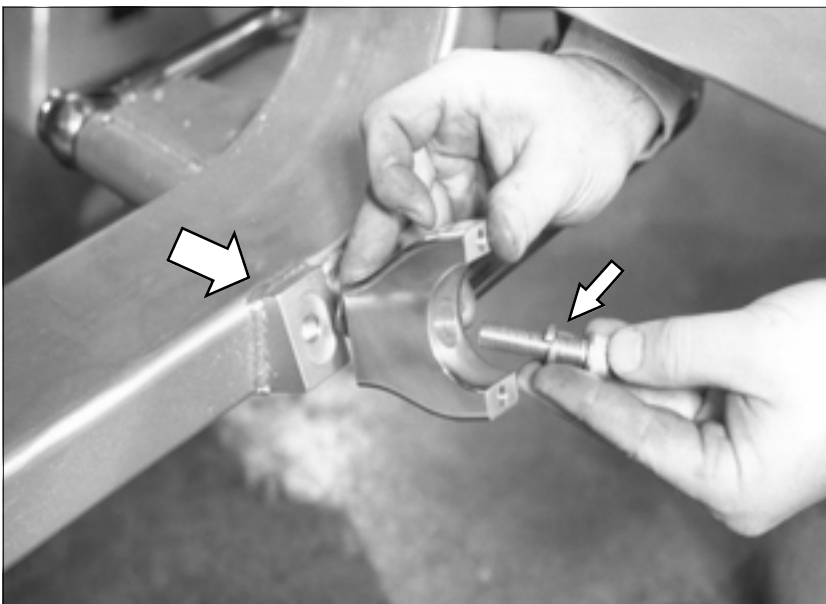

The raised section on the back of the billet clamp matches the milled recess on the mount bosses.

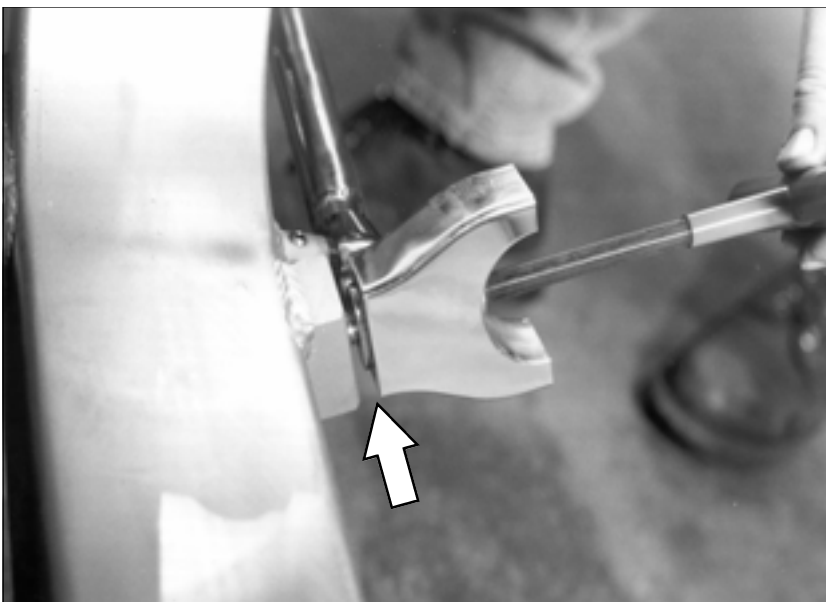



Now repeat the procedure for the other billet rack mount.



With the lower half of both rack mounts installed on the crossmember, the rack itself is set into position.



One of the exclusive design features of our rack and mount is the ability to rotate the rack to provide any desired angle from the steering column to the rack input shaft. Here the shaft is laid almost against the crossmember.



If additional clearance is needed between the pinion and the crossmember, you can raise the pinion up higher. A lower angle will be used to clear the side motor mount bracket. Rotate the rack to minimize the U-joint angle.



Push the rack firmly into each mount. Secure the rack by installing the billet rack clamp caps. Use the provided 5/16-18 x 1" stainless steel socket head allen and custom lock washer. Use a small amount of Loctite™ on the socket head allen.



Tighten the cap with your T-Handle Allen wrench. Once you have the cap tight, the next step will be aligning the front end.



The first step in aligning the new A-arm front suspension is to center the rack in its travel. Placing a U-joint on the rack makes turning it easy.

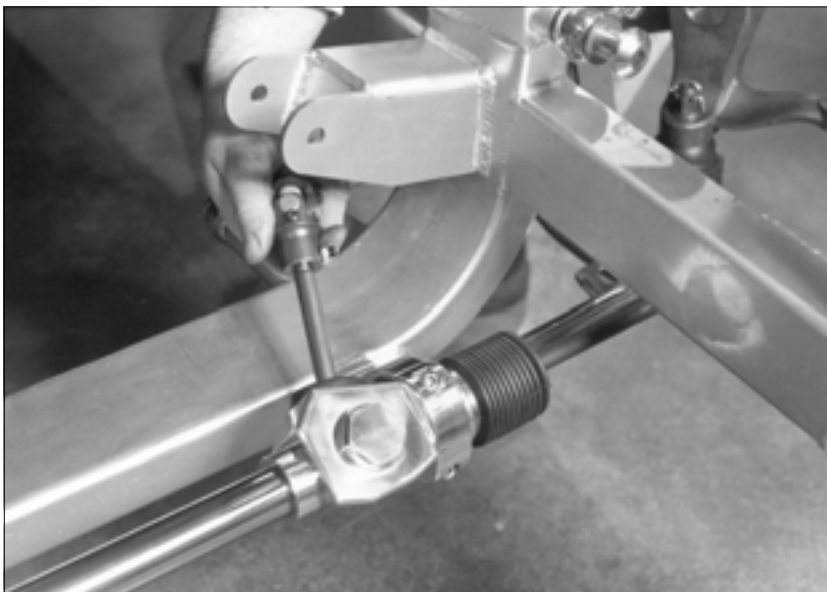

Turn the rack toward the passenger side of the car until it stops (full lock position).

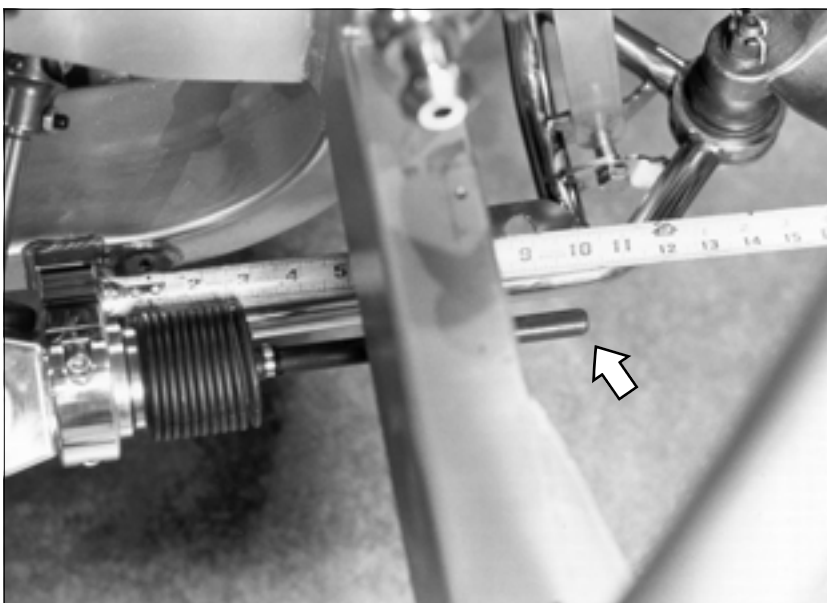

On the driver side, measure and record the distance from the rack mount to the end of the tie rod end. In our example the length is 9 3/4 inches.

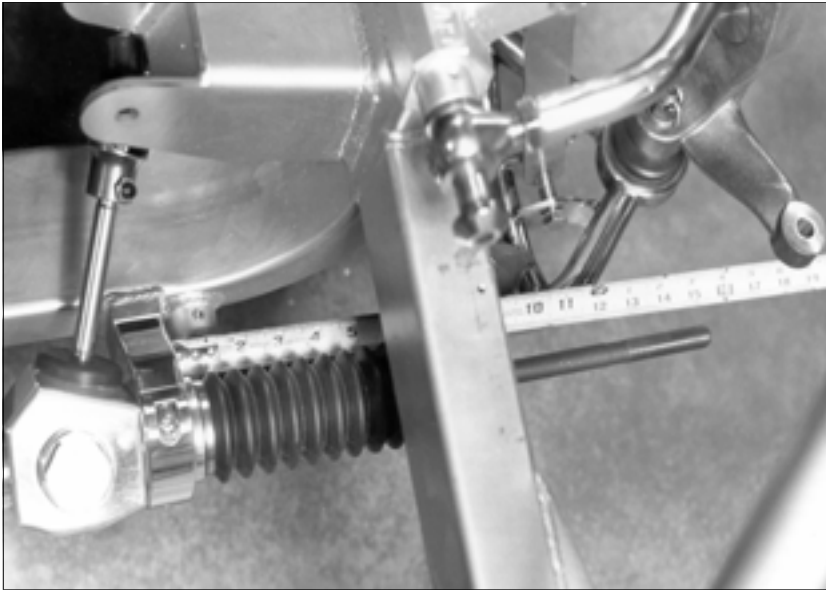

Next, turn the rack all the way to the driver side and record the measurement from the rack clamp to the end of the tie rod. In our example the length is 15 inches.

To calculate how far back to move the rack to center it, use this formula: add the two lengths together and divide by two. This is the distance from the rack clamp on the driver side to the end of the tie rod with the rack centered.

Example:
Driver side length equals 15"
Passenger side length equals 9 3/4"

15" plus 9 3/4" equals 24 3/4" divided by 2 equals 12 3/8.

Turn the rack back toward the passenger side until the length is 12 3/8 inches. Check your rack, do not assume our dimension is correct for your rack.



With the rack & pinion centered, you can set the spindle alignment. Measure from the outside of the frame to the inner edge of the tie rod hole in the steering arm. Set this dimension to 8 5/8 inches. This will make the spindle straight forward while you adjust the tie rod length.



Remove the tie rod end from the steering arm and thread it onto the tie rod until it contacts the jam nut. Next, reinstall the tie rod end into the steering arm. Verify the distance from the frame to the inside of the tie rod end, this should be $8 \frac{5}{8}$ inches as measured earlier.

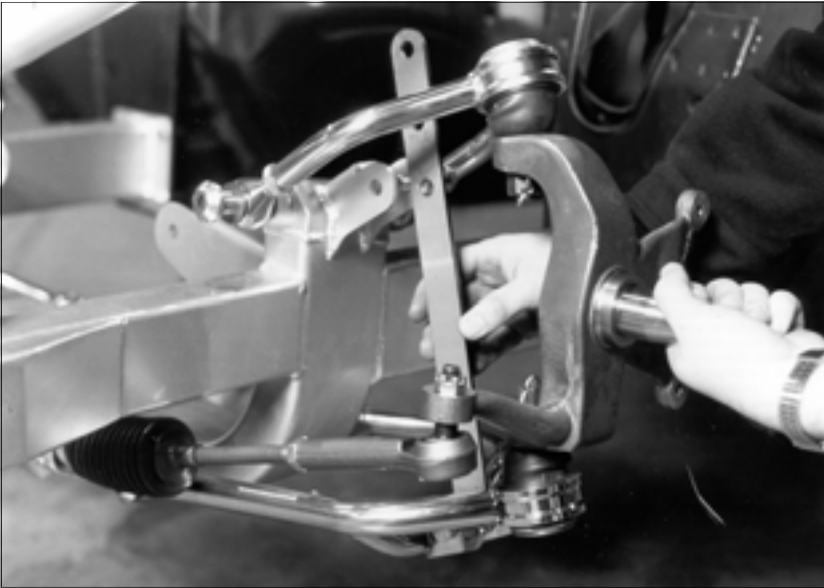

Loosely install the castle nut on the tie rod end. Make sure the spindle moves smoothly from full shock extension to full compression, as indicated by the holes in the shock simulator.

Now, set the shock simulator in the ride height position before you start to check the suspension settings. Do this on the driver and passenger sides.



Front Suspension Alignment

Before checking the front end alignment, check to be sure the car is still level. Put a level on the rocker panel, just inside the door, and adjust the jack stands until the car is level front to rear.

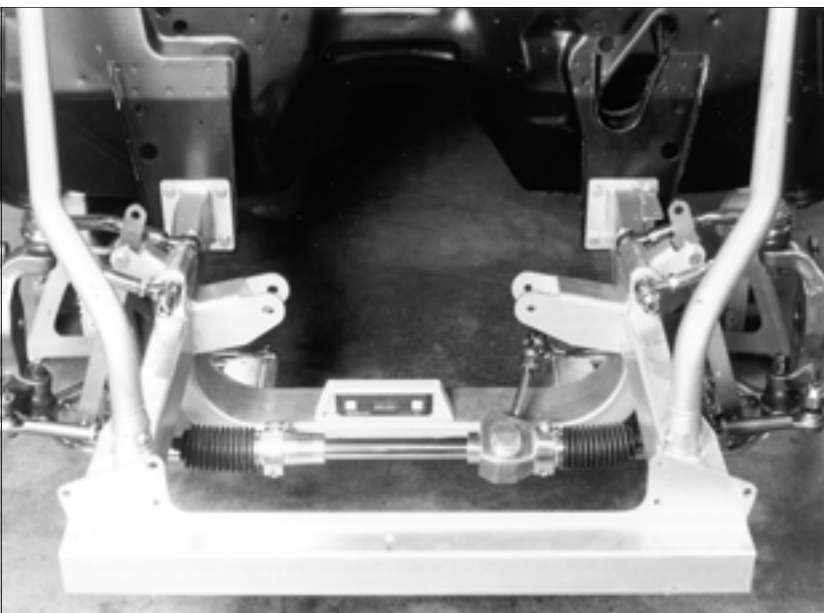

A digital level is preferred for accuracy when setting the front end alignment. Level the crossmember and if needed, adjust the height by placing shims under one of the jack stands.



First, check and record the camber and caster readings, they will be adjusted later.

The caliper mounting bosses are machined perpendicular to the spindle so they are an excellent place for the level.

To check the camber, hold the level against the machined caliper mounting pads on the spindle. Record the reading.



Next, check the caster by installing the 3/8-16 x 1 3/8" caliper mounting socket head allens (supplied in your brake kit) into the threaded bosses on the spindle.



Set the digital level against the caliper mounting bolts. Record the caster reading. Positive caster is when the spindle top is tipped toward the rear of the car when viewed from the side.

We will now fine tune the camber and caster settings.



The adjustment for both caster and camber is made through the adjustable rod ends on the upper A-arms. Moving both rod ends out increases positive camber.

To adjust caster, move the forward rod end out further than the rear. This increases positive caster.

Adjust the upper A-arm rod ends until you have the camber set at zero, or 90 degrees on the digital level and the caster set at 1 to 5 degrees positive. Both sides must be the same.

Remember, if your car has a forward rake when sitting on the ground the positive caster will be decreased by the angle of the bodies rake. Three degrees of positive caster with the body level, will only be 1 degree of positive caster with a 2 degree body rake. Adjust one rod end at a time one-half turn until you have the correct setting. Repeat for the passenger side before going to the next step.



The next step is setting the toe-in. Cut two pieces of 3/4 inch tubing or electrical conduit, 26 inches long. Drill a 3/8 inch hole through each tube 9 inches from one end. These tubes will assist in setting the toe-in.

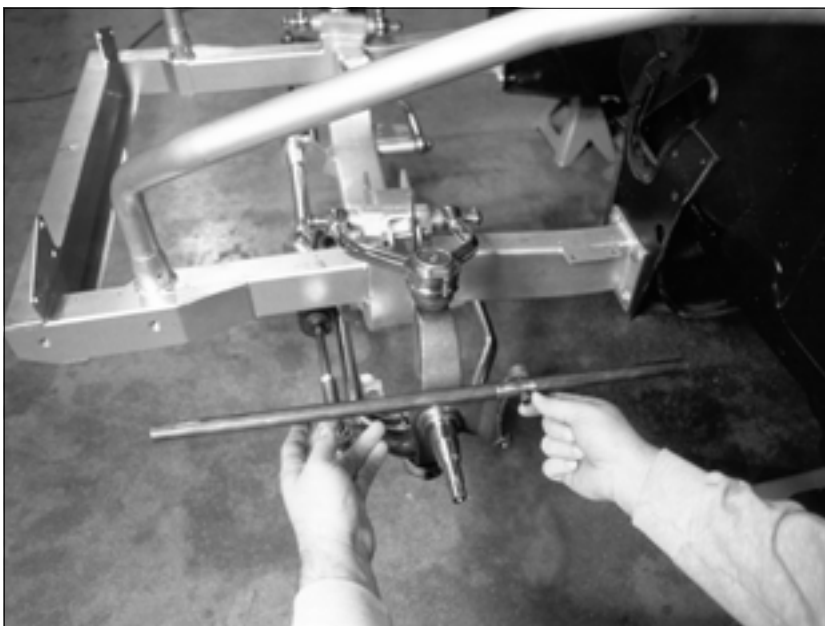

Bolt the tube to the upper caliper mounting boss with the long end to the front of the car. The 26 inch length simulates the tire diameter and drilling the hole 9 inches from the end centers the bar over the spindle.



Next, set the bar level and tighten it down. Do this on both the driver and passenger sides.

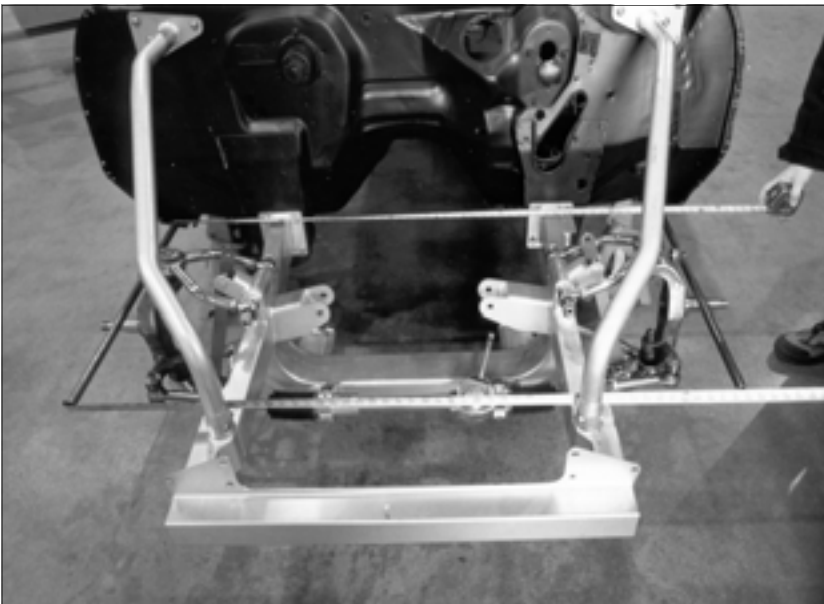

Using two tape measures, measure the outside width at the front and the rear of the tubes. The front dimension should be $\frac{1}{8}$ to $\frac{3}{16}$ less than the rear, this is the total amount of toe-in. Record the front and rear dimensions and calculate the amount of toe-in by subtracting the front measurement from the rear.



To adjust the toe-in, rotate the tie rod ends to move the spindle in or out as required. Make sure to rotate both the driver and passenger side the same amount. One-half revolution of both tie rod ends will change the toe-in by approximately $\frac{1}{4}$ inch, front to back.

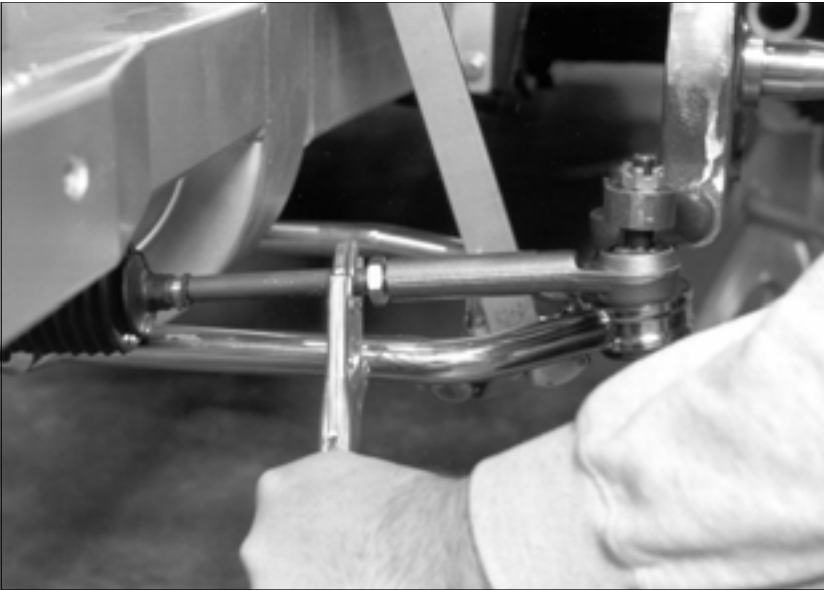

If rotating the tie rod end 360 degrees changes the toe-in too much, use the rack tie rod to make smaller adjustments. Put the tie rod end in the steering arm and snug the castle nut before adjusting. Use vise-grips to grab onto the tie rod and rotate it to adjust the length. Be careful to turn both tie rods the same amount.



When turning the tie rods, the rubber boot will “wind up” on the tie rod. Once the toe-in is adjusted, use a pliers to “unwind” the boot around the tie rod. Gently grab onto the outer boot clamp and twist it back around until the boots are straight. The jam nuts can now be tighten against the tie rod ends.

Verify caster, camber and toe-in are correct before proceeding.

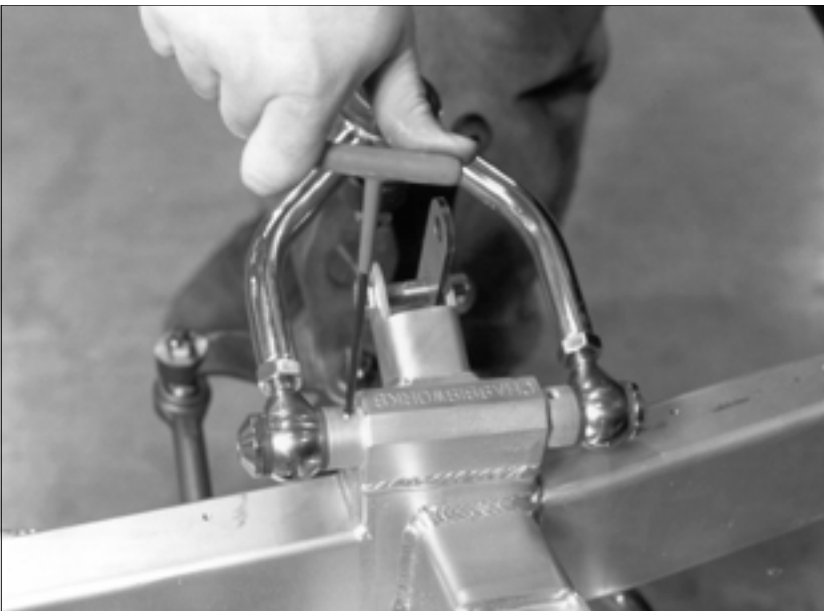

Once the camber, caster, and toe-in are set, tighten down the A-arm bolts and jam nuts, and install the set screws with a drop of Loctite™.



Next, you can final assemble the tie rod ends. Start by installing the grease zerk fitting in the hole at the bottom.



Install the rubber boot.



Put the tie rod ends back into the steering arm. Tighten the castle nut and, install and bend the cotter pin like you did on the balljoints.

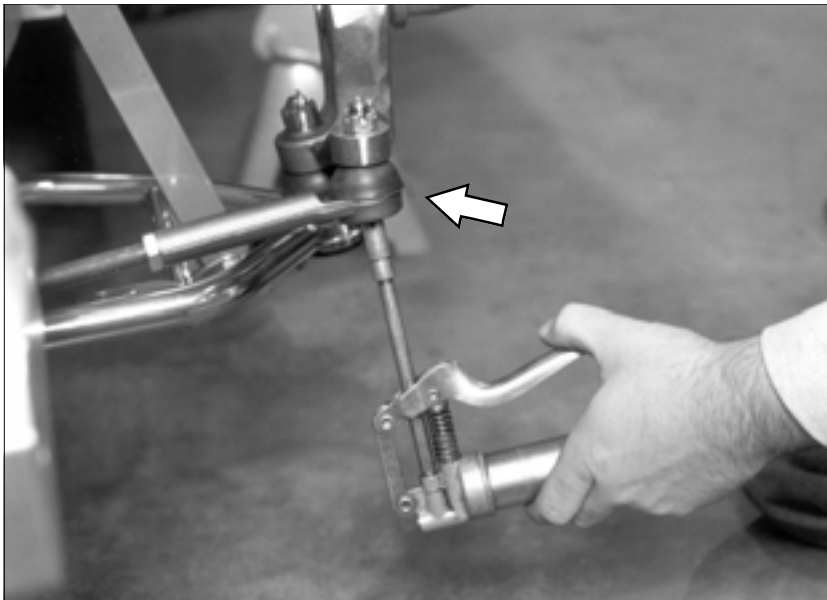

Grease the tie rod end with a small grease gun. Add only enough grease until a small amount starts to come out from under the rubber boot.



Grease the upper and lower balljoints. Install the zerk fittings and inject grease with a grease gun. Put only enough grease in to make the balljoint rubber boot bulge out on the side. If you are installing the balljoint caps, remove the zerk fitting.



Set the stainless steel cap over the balljoint.



The caps are held in place with the countersunk stainless steel allen screws provided. They screw into the hole where the grease zerk was just removed. Be sure to remove all grease from the threads in the balljoint and Loctite™ the countersunk allen head screw in place.



Use the same procedure to install the lower balljoint caps.

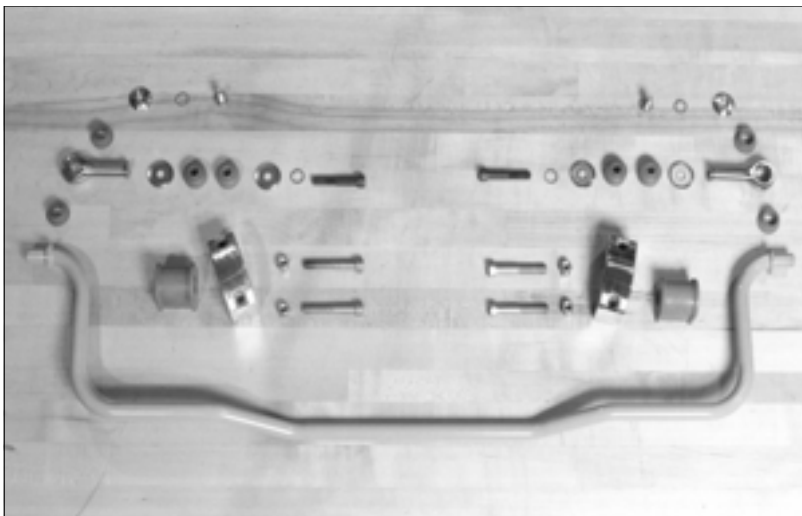

Installing Antiroll Bar

Next, install the antiroll bar.

These are the components of the antiroll bar kit.



To prevent the urethane bushings from squeaking in action, use the supplied silicone grease to coat all sides of the urethane bushing that contact a metal surface. A thin screwdriver can be used to smear it around inside the bushing. Take extra care not to get this grease all over, it's very sticky.



To open up the bushings, use the handle end of the balljoint wrench that is included in the suspension kit.



Once the slot in the bushing is opened, slide it over the antiroll bar near the 90 degree bend.

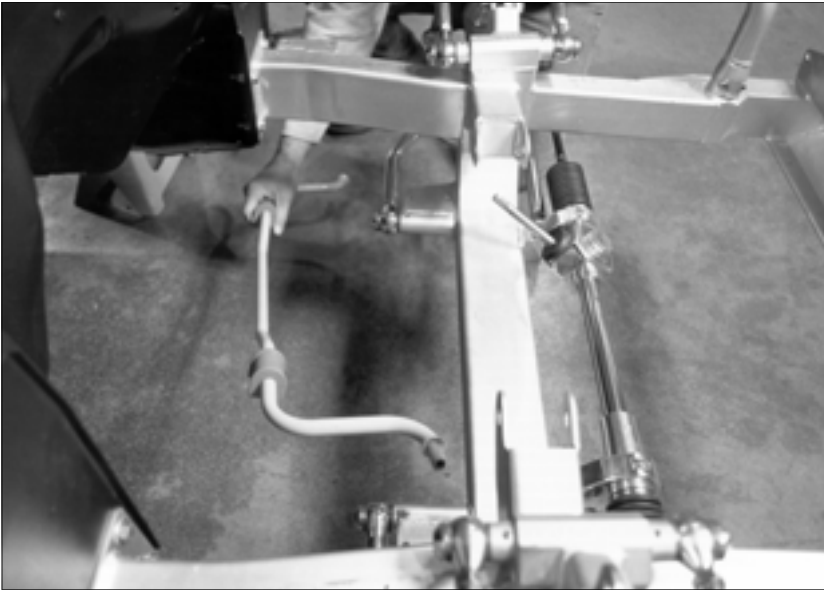

With both bushings on the bar, bring it up from under the car and set it in position.

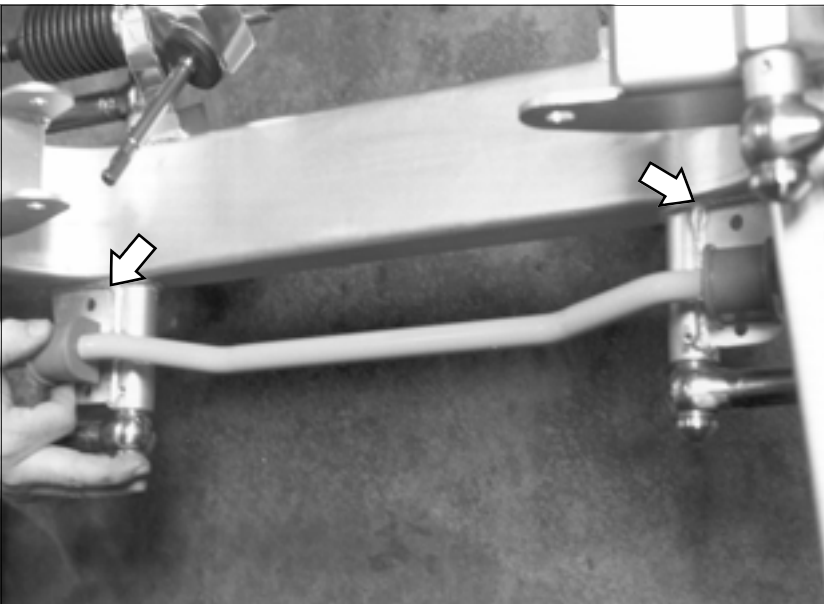

Center the bushings on the mounting pads welded to your frame.

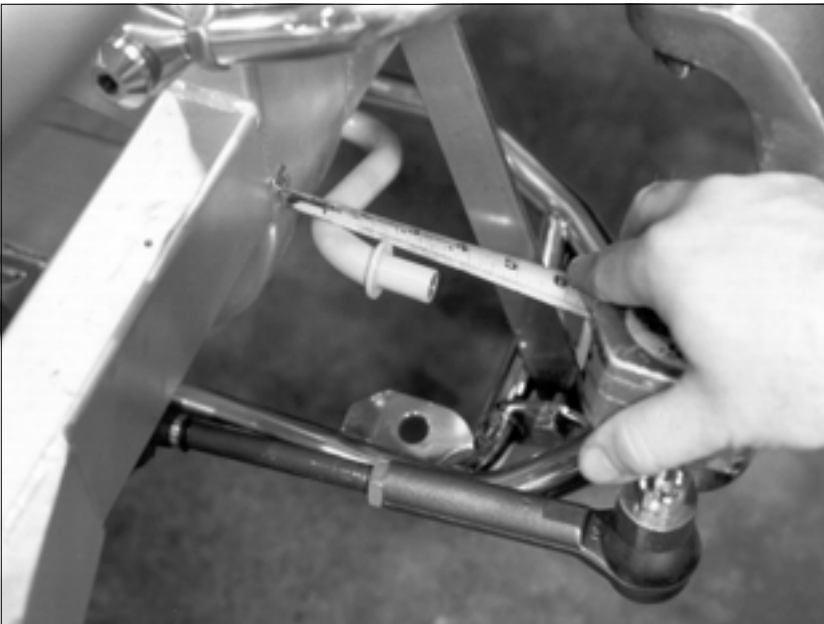

Center the antiroll bar in the frame by measuring from the side of the frame to the end of the bar on the driver and passenger sides.

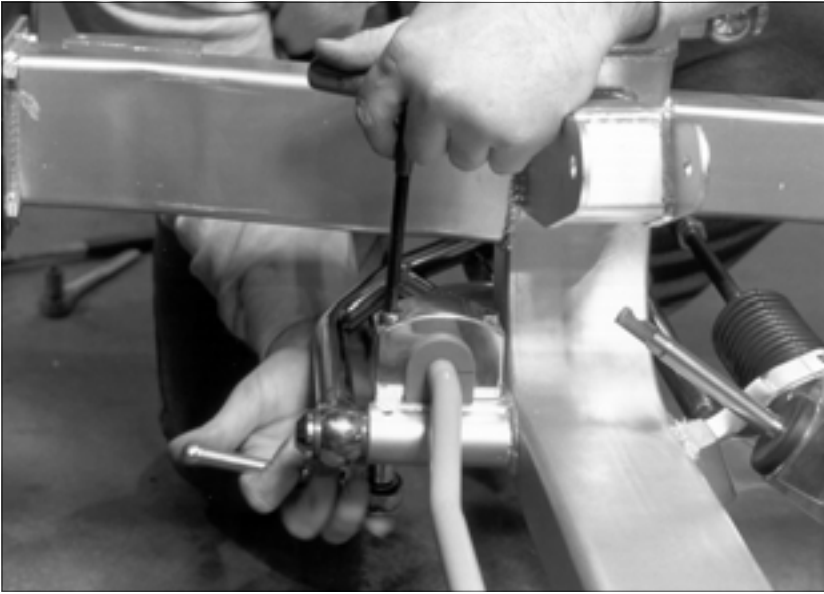

Slide the billet aluminum cap over the bushing and secure with the 3/8-16 x 2 1/2" socket head allen and locknuts provided.



Put the urethane bushings into the upper antiroll-bar-link eyebolt.



Coat the bushings with the silicone grease.



Next, slide the link eyebolt onto the end of the antiroll bar.



Shown here is the hardware used to attach the link eyebolt to the antiroll bar.



Attach the link eyebolt to the antiroll bar. Place the internal tooth lock washer next to the head of the 3/8-16 x 3/4" button head allen and the beveled stainless steel washer. Apply Loctite™ to the button head allen and tighten.



Put the star lock washer, bushing washer and one urethane bushing on the 3/8-16 x 2 1/4 socket head allen. This attaches the link eyebolt to the lower A-arm. Apply silicone grease to the bushing on all surfaces.

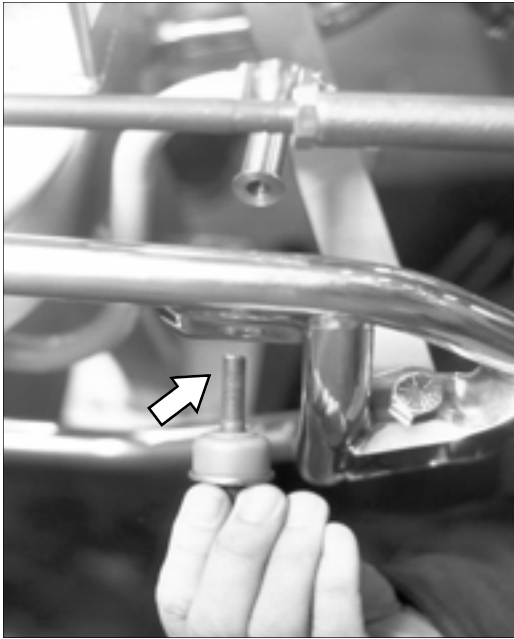

Insert the lower bushing assembly into the lower A-arm mount bracket.



Grease the upper bushing and slide it and the other bushing washer over the bolt.



Apply Loctite™ to the bolt. Push down on the antiroll bar and thread the bolt into the end of the link eyebolt.



Use the T-handle Allen wrench to tighten the bolt from under the lower A-arm. Tighten only until the urethane bushing begins to crush.

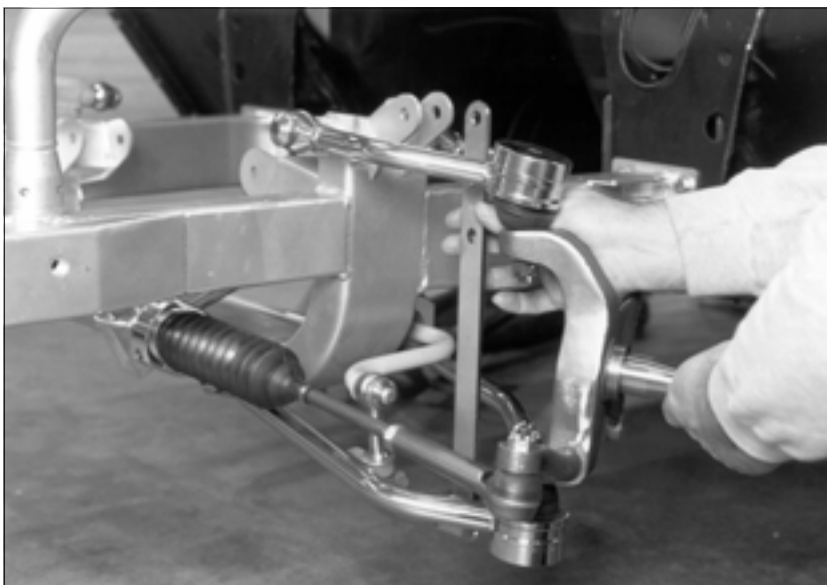

After finishing the antiroll bar installation, run the suspension through its travel full shock extension to full shock compression. Do this with the spindle turned full left, full right, and centered. Everything should move without binding. Because the antiroll bar makes independent installation difficult, you will have to do the driver and passenger sides at the same time.

Installing Shocks and Springs

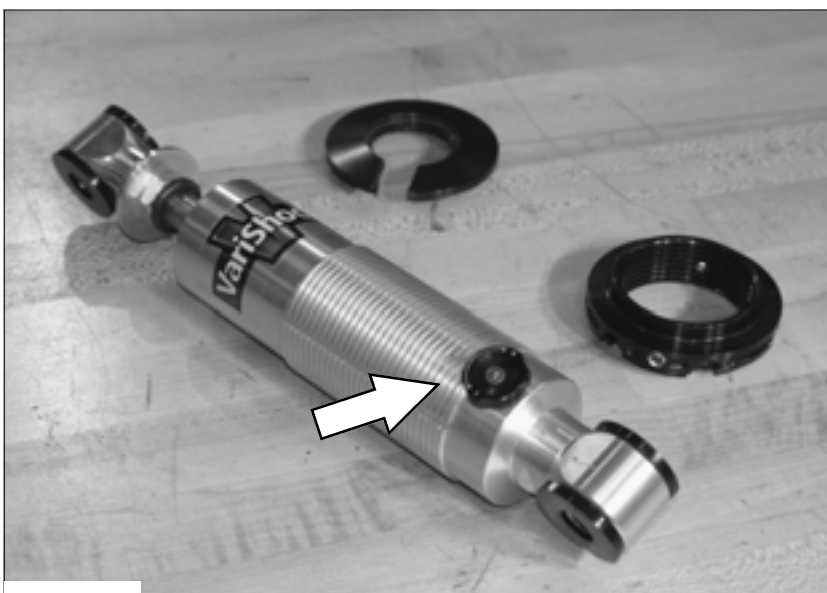

The front suspension kit includes the VariShock Quickset 1 externally adjustable coilover shocks with urethane bushings. The knob on the bottom is used to change the ride quality and handling of the vehicle.

Optionally available is a VariShock Quickset 2 double adjustable coilover.

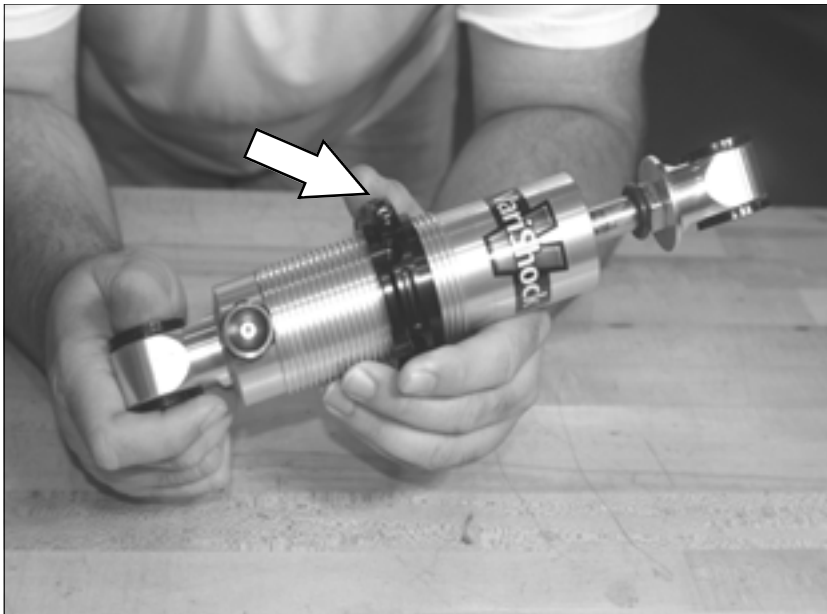

Screw the spring seat adjuster onto the shock. The set screw locking ball allows the spring seat height to be adjusted in ½ turn increments and then locked once the desired spring height is set.

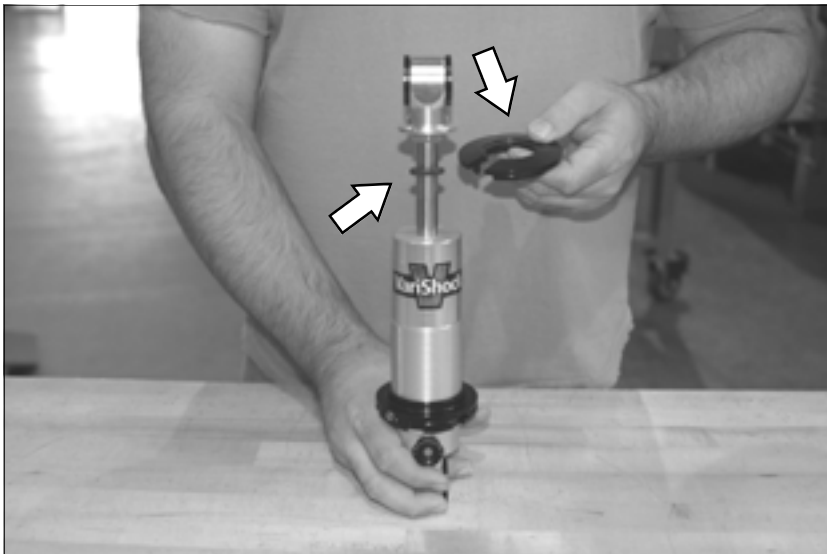

This upper spring seat holds the spring in place at the top of the shock. The slot allows the spring seat to be inserted after the spring is in place.

Slide the rubber bumper down the shock shaft before installing the spring.

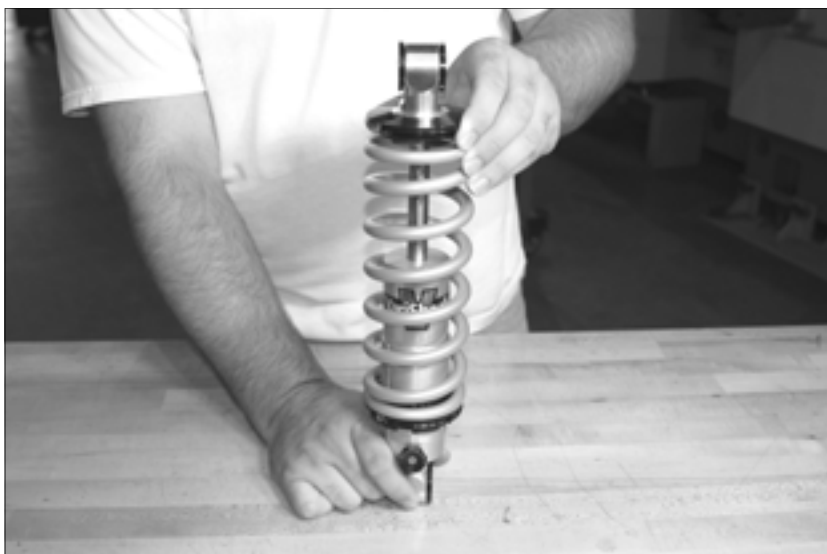

After dropping the spring over the shock, slide the upper spring seat over the shaft.



Next, turn the shock over and tighten the spring seat against the spring. After the spring seat makes contact with the spring, turn it one-half of a revolution. This will add a small amount of preload to the coil spring. Tighten the set screw locking ball with an allen wrench. With the spring seat at this position, adjusting the spring seat up or down 1/2-inch can make small changes in the vehicle ride height.

The designed ride height of the suspension has the compressed coilover at 12" eye to eye. If you install a 195/65-15 tire on a 6" wide 15" diameter 3 1/2" back space wheel, the tire will have 6 1/2" of thread diameter of 25" and a rolling radius of 12". This will hold the bottom of the crossmember 4 1/2" off the ground. The tire will hold the spindle centerline 12" off the ground. If you use a larger or smaller diameter tire, the crossmember



These are the stainless steel shock mounting spuds used at the top and bottom of the shocks. If you did not purchase these, use the 1/2 x 2-1/2 bolts and locknuts provided with your suspension kit.

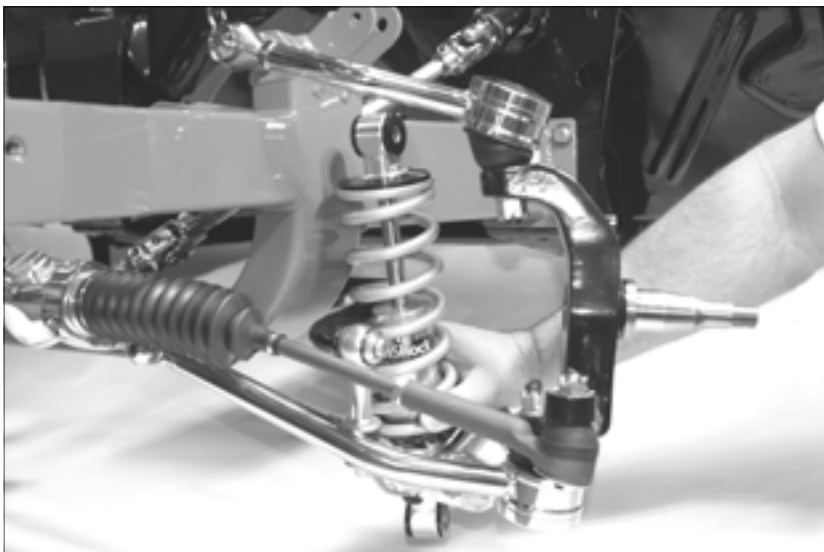

Insert the shock from the bottom. It will fit between the antiroll bar and the lower A-arm shock mount cross tube.



Install the lower shock spud first. Insert the male shock spud from the front of the car into the lower A-arm. Insert the female part of the spud from the back, it acts as the nut. Use Loctite™ to secure threads.

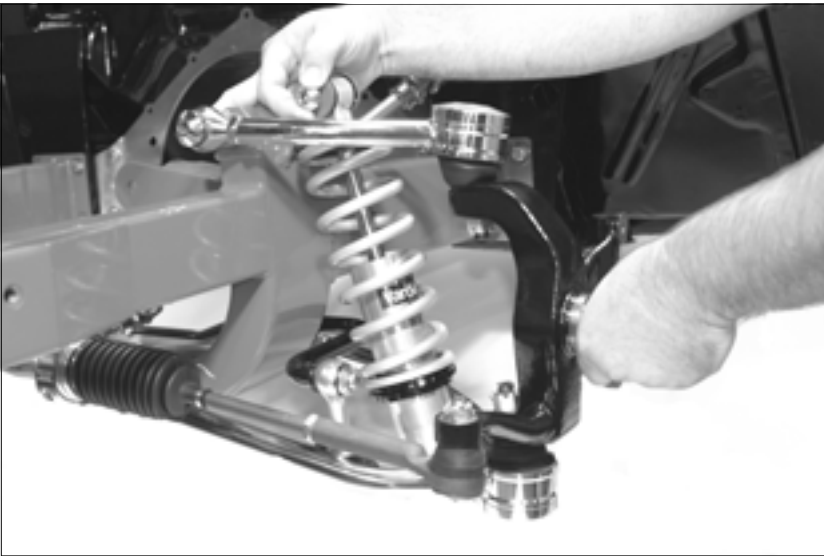

Using the spindle shaft as a handle, line up the top eye of the shock in the upper mount and slide the male spud in. Insert the female part of the spud from the back, it acts as the nut. Use Loctite™ to secure threads.



With both halves in place, use two Allen wrenches to tighten the spud together. Tighten them until they stop, the correct amount of crush is calculated into their length.

Installing Brakes

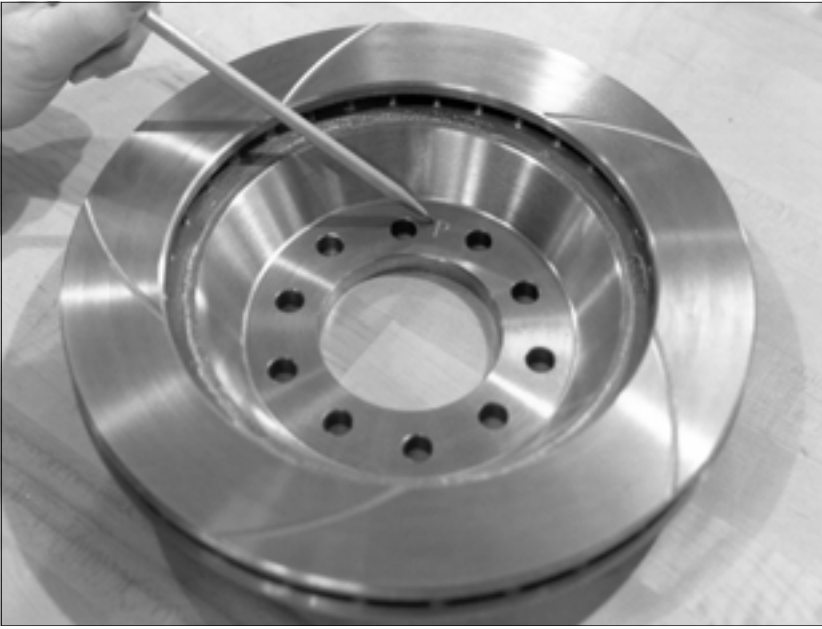

The 11 3/4 inch vented rotors are directional. The passenger side rotor is identified by the "P" machined on the inside. There is a "D" on the driver side rotor.

These brakes require at least a 15" diameter wheel, however, even some 15" wheels may not clear. Verify you have at least 1/4" of wheel clearance from all brake components.

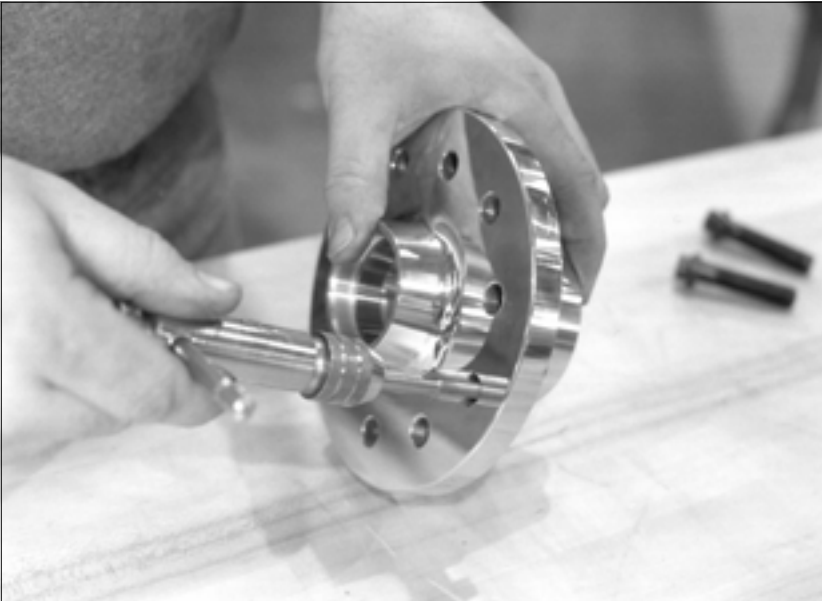

The billet aluminum hubs have threaded stud mounting holes for both 4 1/2 and 4 3/4 inch bolt circles.

Choose the bolt circle that matches your wheels and chase the threads with a 1/2-20 tap.

After chasing the threads, it is a good idea to blow them out with an air hose making sure no debris remains in the holes.

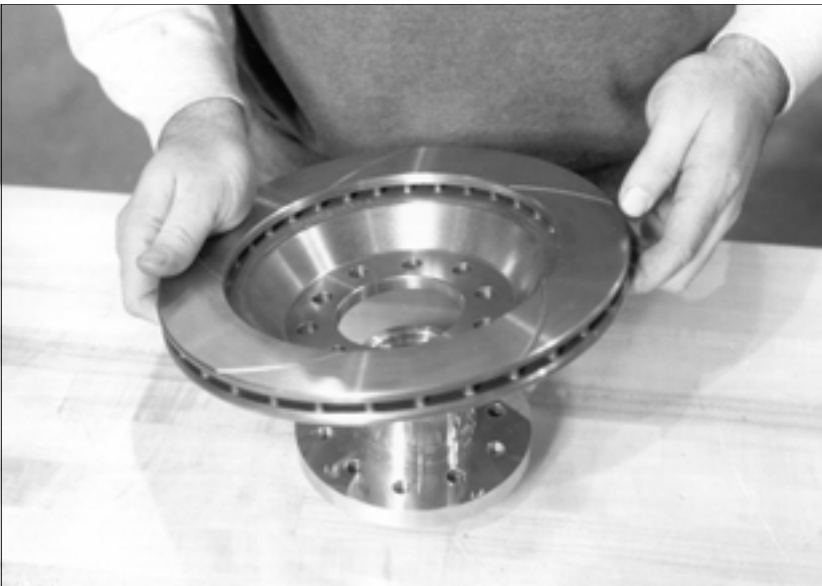

Set the rotor over the back side of the billet hub. The larger bearing race snout on the hub is the back side. Line up the bolt circles on the hub and the rotor.



Add a drop of Loctite™ to the threads, up near the shoulder and insert the studs through the proper series of holes. The provided 12 point bolts are 2 1/4 inches long. If you need a longer wheel stud for thicker wheels, 3 inch long studs are available from Chassisworks.



Tighten the studs from the backside of the assembly. You're ready to install the inner wheel bearing and seal.



The bearing races are pressed in the billet hub from the factory. You must pack the wheel bearing before installing it. In the photo, a wheel bearing packer is shown. If you do not have one available, hand packing the bearing is okay. If you are unsure how to pack the bearing, refer to an auto repair manual for assistance.



After the bearing is packed, drop it in the bearing race. The inner wheel bearing seal is then positioned on the hub.



Place the hub on a wood surface before installing the seal. Using a hammer and seal installer, drive the seal into the hub making sure it's fully seated.

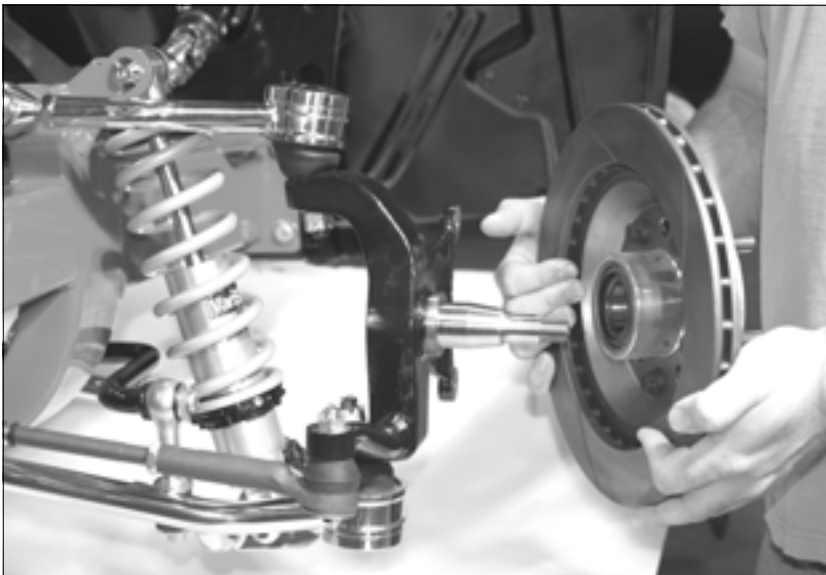

With the inner bearing and seal in place, slide the hub and rotor assembly onto the correct spindle (remember, the rotors are directional).

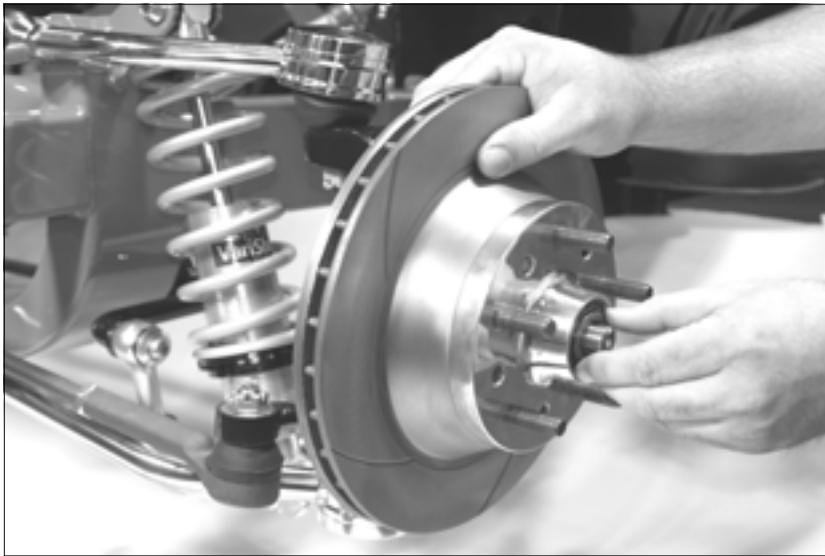

Pack the outer wheel bearing as you did the inner one. Slide the bearing into the race.

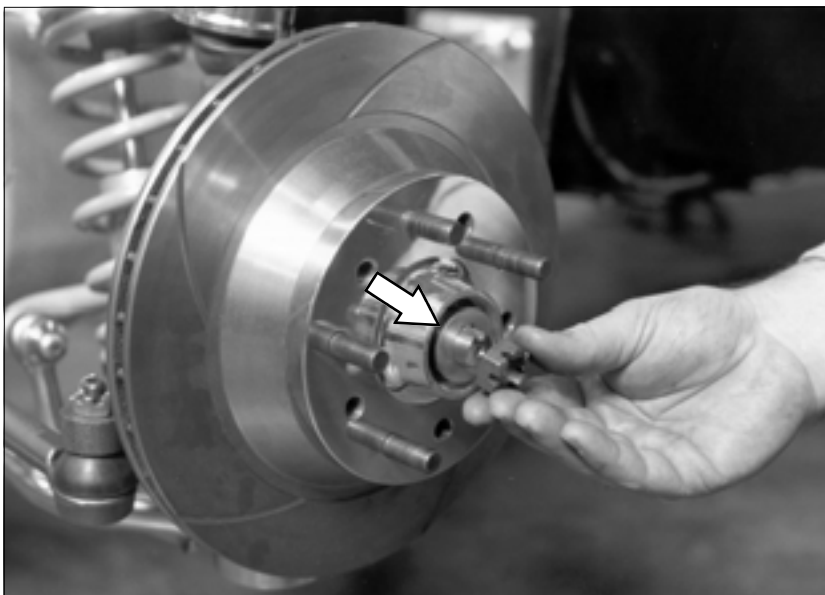

Slide the washer over the spindle shaft and install the castle nut.

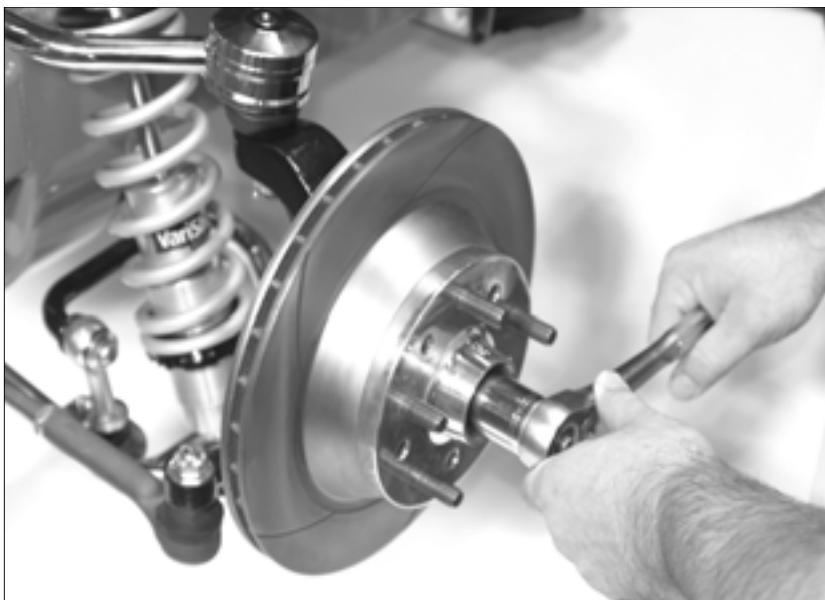

To fully seat the bearings, tighten the castle nut to 12 lb-ft while turning the rotor assembly forward by hand. This will remove any grease which could cause excessive wheel bearing play. Back-off the castle nut to the "just loose" position and then hand tighten. There will be .001 to .005 inches of end play when the wheel bearings are properly adjusted.

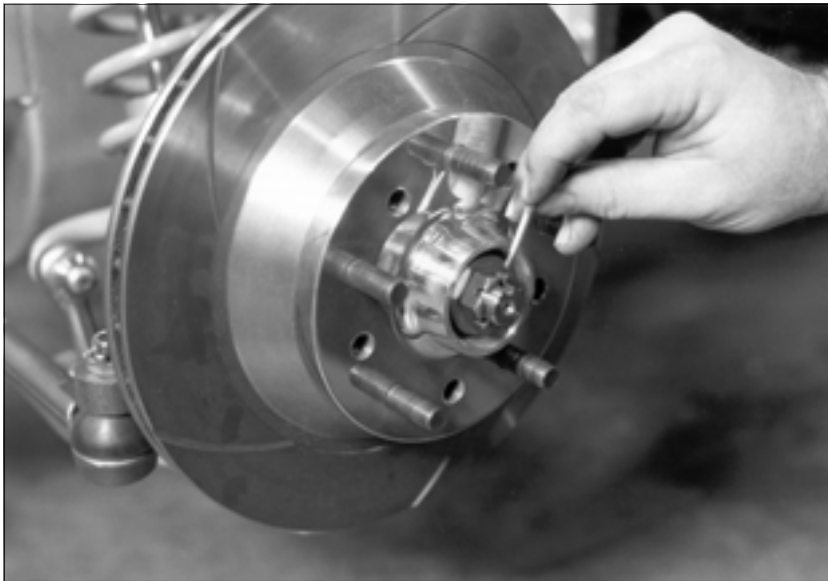

After the wheel bearings are tight, insert the cotter pin through the castle nut and the hole in the end of the spindle shaft. Do not tighten the castle nut when aligning the cotter pin, only loosen it.

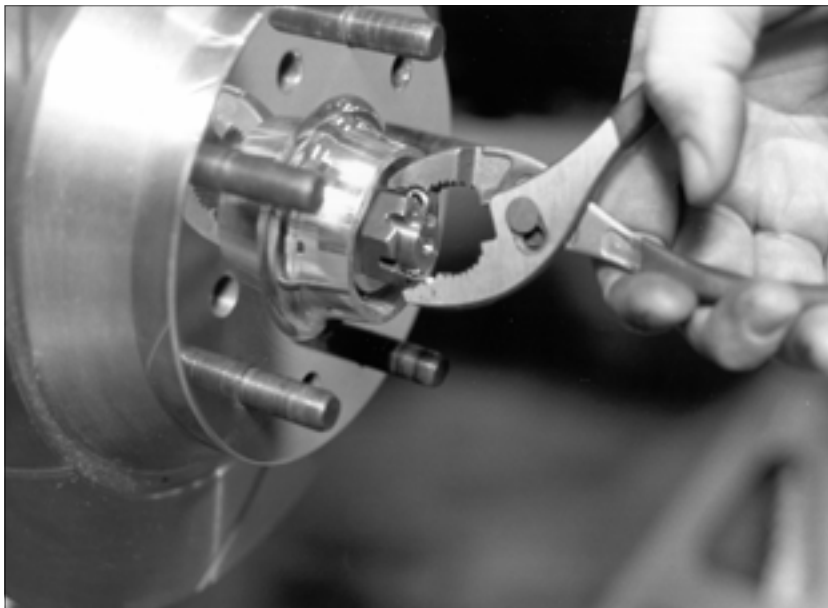

Use the same procedure you used on the balljoints to fold the cotter pin legs.

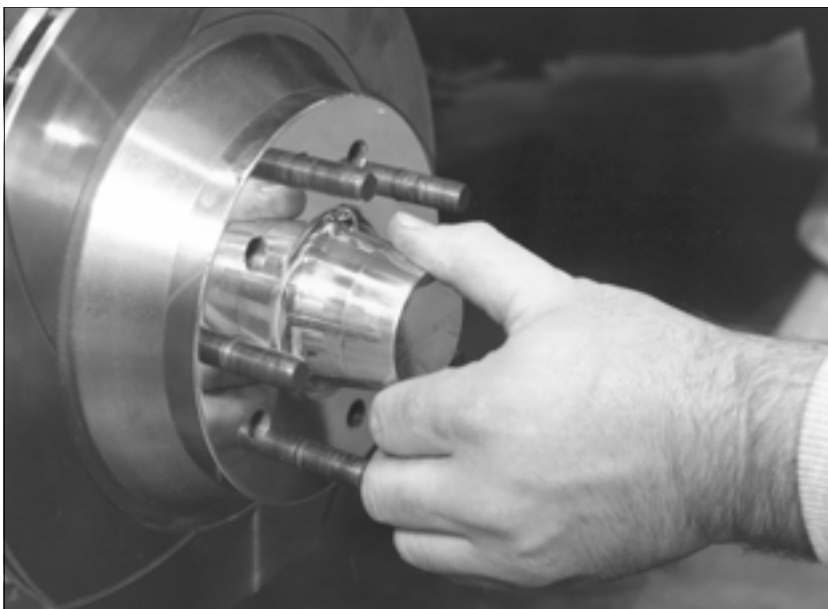

Apply anti-seize to the threads of the screw-on dust cap. Screw the dust cap onto the hub. It only needs to be hand tightened, the o-ring inside will keep it from coming loose.



Next, install the Wilwood brake calipers. Start by inserting the brake pads into the caliper, one on each side of the rotor slot with the metal backing toward the pistons.



Slide the caliper with the pads installed over the rotor and the caliper mounting pads on the spindle. Use the 3/8-16 x 1 3/8 socket head allens, lock washers, and flat washers provided in your brake kit to mount the calipers. The lock washer goes against the head of the fastener.

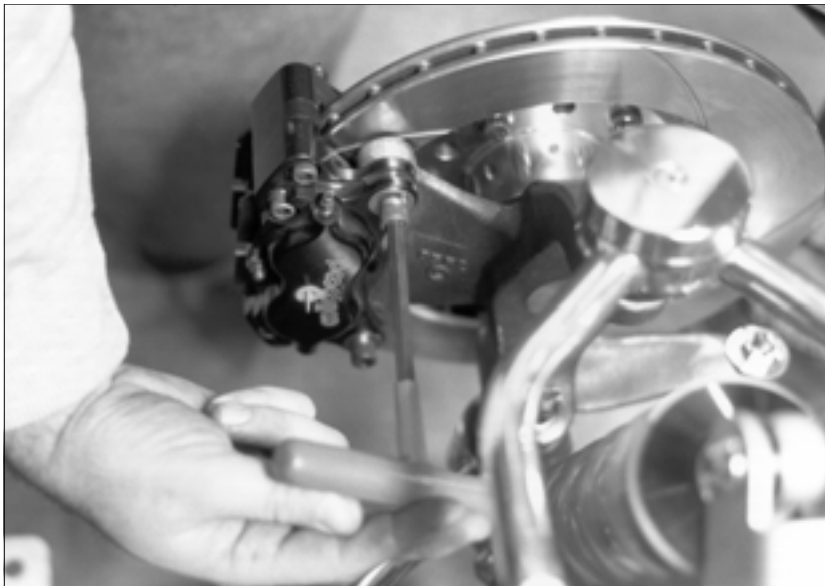

Use the T-handle Allen wrench to tighten the mounting bolts. Rotate the rotor assembly slowly to check for any clearance problems between the rotor and the caliper.



Finally, bolt your wheel and tire on the hub and check again to be sure there is at least 1/4" clearance between the caliper and the wheel. There are differences in wheel manufacturer's tolerances. Make sure your wheel turns freely. **Do not** use positive offset wheels with this suspension system.



Next, remove the plastic plug protecting the inlet port of the Wilwood caliper to start the installation of the stainless steel brake lines.

Coat the 1/8 pipe threads of the 90 degree brake line adapter fitting with Loctite™ teflon sealing compound.

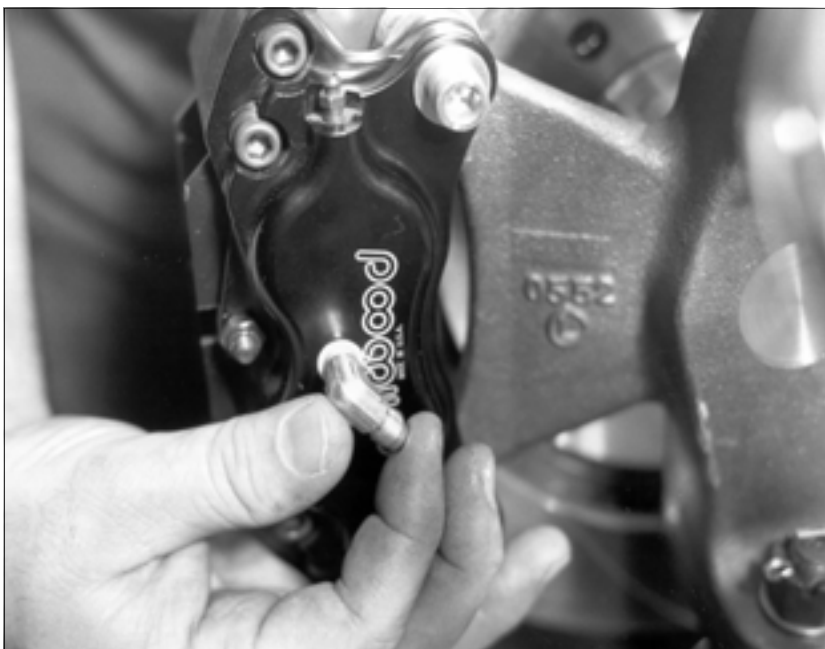

Thread the fitting into the caliper. Be sure to start it straight so you do not cross thread it. If the threads in the caliper get damaged you will have to replace the caliper.



Use a 3/8" wrench to tighten the brake line adapter fitting. The hose end of the fitting should point toward the lower caliper mounting bolt when tight.

Remember, the caliper is aluminum and the fitting is steel. Do not over tighten and strip the threads in the caliper.



Thread the swivel end of the stainless steel brake line onto the adapter fitting until it is finger tight.



Slide the brake line frame tab over the other end of the stainless steel brake line.



Install the jam nut and just finger tighten for now.



Clamp the brake line frame tab to the frame rail, centered directly under the head of the upper A-arm mounting stud and 1 1/2 inches down from the top of the frame rail.

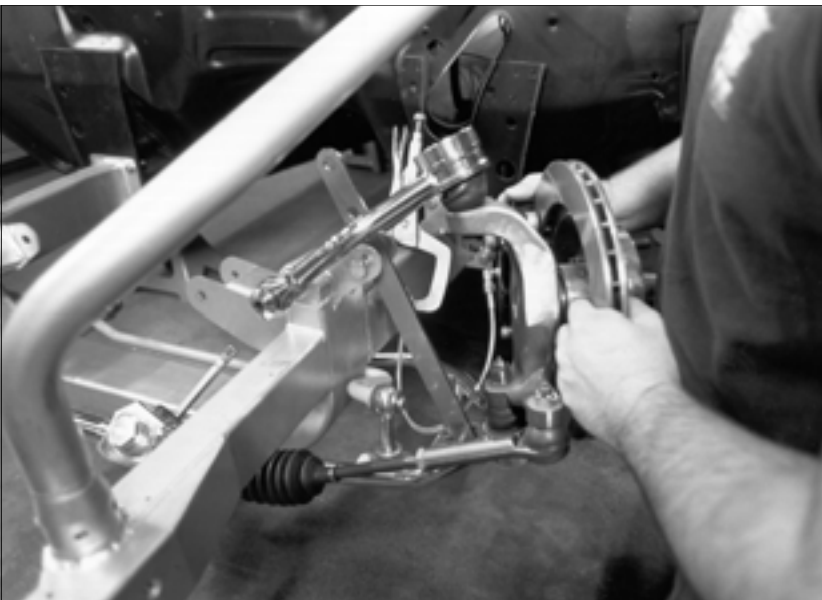

Next, check the brake line for clearance to all suspension parts. Also, be sure the brake line is not stretching or binding while the suspension goes through its full travel and its lock to lock turning radius.

Unbolt the passenger side end of the anti-roll bar, remove the driver side coilover shock and install the shock simulator in the fully compressed position. Turn the spindle to the full left lock position, check the brake line for binding.



Move the spindle to full right lock, check the brake line for any binding.



Move the shock simulator to the full extension setting, turn the spindle to full right lock position. Check the brake to be sure it is not stretched.

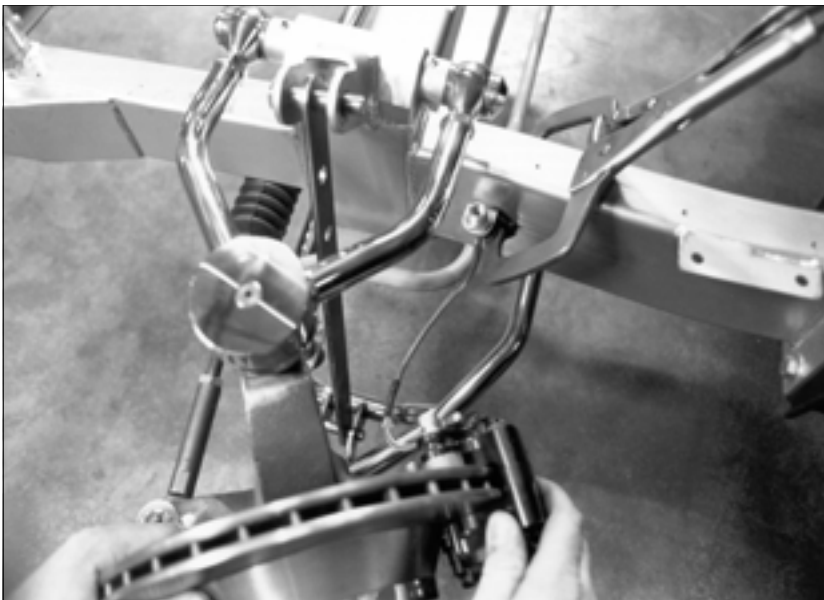

Turn the spindle to the full left lock position, check the brake line for binding.



Use a center punch to mark the forward hole location needed to mount the brake line frame tabs.



Drill one hole in the frame rail using a No. 21 drill bit (.159 diameter). Tap this hole with a 10-32 tap for the 10-32 x 3/8" stainless steel button head allens used to mount the brake line frame tab.

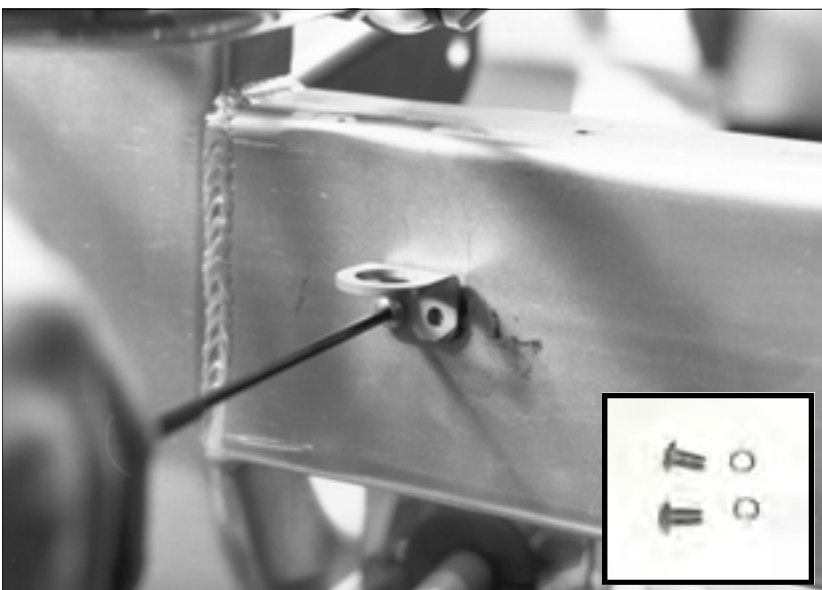

Remove the brake line frame tab from the end of the brake line.

Attach the tab to the frame rail with the stainless steel 10-32 x 3/8" button head and 3/16 high collar lockwasher provided. Use an allen wrench to tighten the button head.



Level the tab and use the rear hole as a guide to drill the frame rail. Use the 10-32 tap to thread the frame rail.

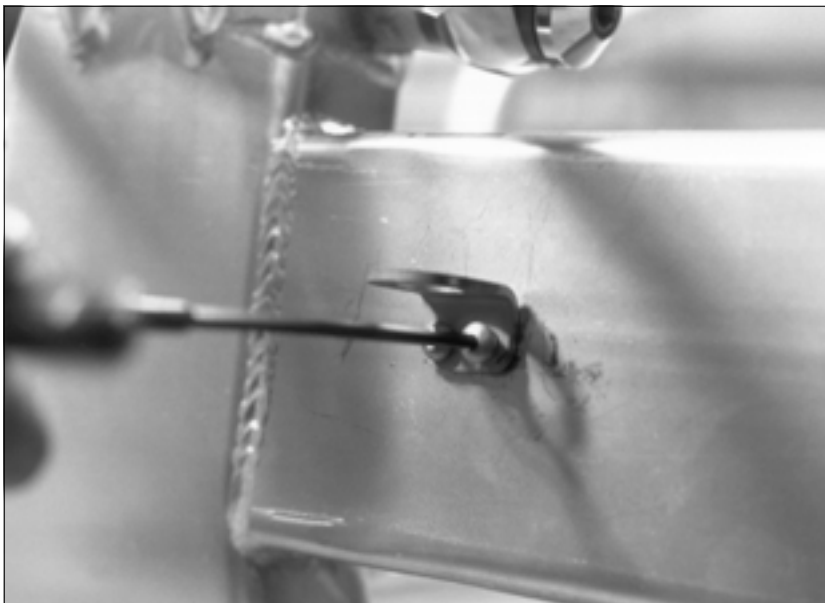

Again use the stainless steel 10-32 x 3/8 button head allen and high collar lockwasher to finish attaching the tab to the frame rail.



Insert the brake line through the tab and tighten using one wrench to hold the brake line and another to tighten the jam nut.



You can now final tighten the brake line at the caliper adapter.

Repeat this procedure for the passenger side brake line assembly.

Selecting an A-Arm Crossmember

This worksheet is used to determine the front-hub to front-hub width needed to fit your wheel and tire combination. Use the actual wheel and tire combination you will be running when filling out this worksheet. Write all of the measurements on a separate piece of paper. Fill in the worksheet after you have double-checked all dimensions.

Using a front tire with a rolling radius of 12 inches or a 25 inch diameter, the cross-member's ride height will be 4-1/2 inches from the ground. If you are using a taller or shorter tire the crossmember ride height will change proportionately. The distance from the outside of the crossmember to the hub-face is a constant 13-1/2 inches. Do not try to figure your crossmember width by matching an existing frame width. You will end up with the incorrect front hub to hub width. The minimum wheel diameter needed to clear our 11 3/4 inch disc brakes is 15 inch.

Fill in your name, car year & model, and sign the worksheet at the top, leave the SO# blank.

The following are examples of how to fill in the top rows of questions.

TIRE SIZE: P195/65-15 BF Goodrich

WHEEL SIZE: 15 X 6 Weld Wheel

WHEEL SPACING: 4 inches

WHEEL BASE: Distance from the front axle centerline to rear axle centerline (only needed when ordering 2x4 full frame): 108 inches

The following are definitions of the lettered blanks. Using these definitions, enter the dimensions on the sheet in the following order.

A: Distance from the wheel mounting surface to the outside tire sidewall.

1. Lay the tire on the floor with the outside sidewall down. Measure from the ground to the wheel mounting surface, enter on the worksheet as "A".

B: Outside tire clearance from the tire outside sidewall to inner fender lip.

2. We recommend 3 inches of outside tire clearance on driver and passenger sides. Your application may require more or less clearance. To determine the proper amount of tire clearance from the inside fender-lip, place the mounted wheel and tire into the front wheel opening with the car at ride height. Place the tire as close to the inner fender-lip as possible. Move the tire in until there is enough clearance between the inner fender lip and tire sidewall to rotate the tire 30 degrees in each direction from straight forward. Measure from the inner fender-lip to the outside tire sidewall, enter on the worksheet as "B".

C: This is a calculation equaling the difference between the hub to hub width and the inner fender width.

3. Use this formula, enter on the worksheet as "C".

$$(A+B) \times 2 = C$$

D: Width of the car from the driver inside front fender-lip to the passenger inside front fender-lip.

4. Measure the front fender inner lip width from driver to passenger side, enter on worksheet as "D".

E: Hub to hub width from the inside wheel to inside wheel mounting surfaces.

5. This dimension will be calculated below. To determine the hub to hub dimension "E" by using this formula:

$$D - C = E$$

F: Crossmember outside width needed. It is 13-1/2 inches from the outside of the crossmember to the hub on each side, times two for a total of 27 inches, this is a constant dimension. After you finish calculating your crossmember width round it up or down to the nearest full inch. Crossmembers are available in one inch increments from 24 to 38 inches outside width.

6. To determine the crossmember outside width dimension "F," use this formula:

$$E - 27 = F$$

In Our Example:

A= 4.0 B= 3.0 C= 14.0 D= 69.0 E= 55.0 F= 28.0

C $(4.0+3.0) \times 2 = 14.0$

E $69.0 - 14.0 = 55.0$

F $55.0 - 27.0 = 28.0$

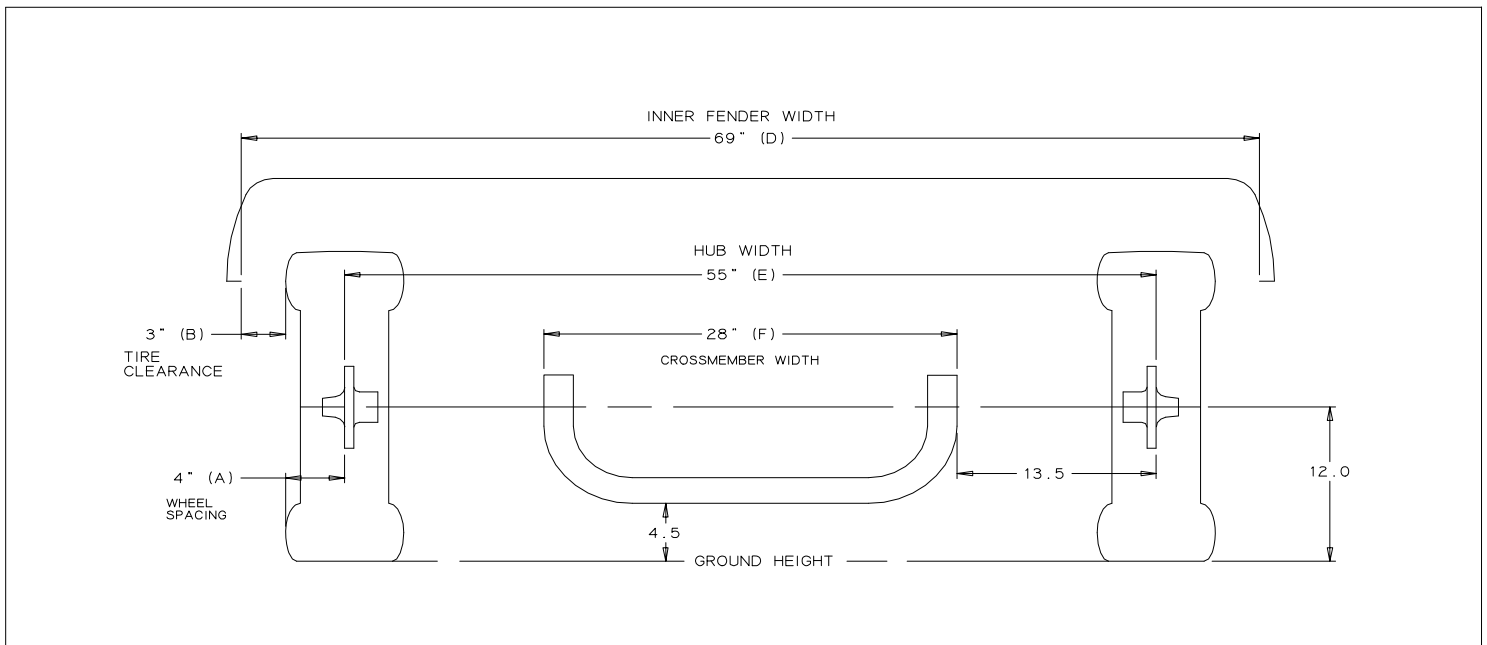

After double checking all dimensions, enter them on the worksheet. Sign the worksheet and fax it to (916) 388-0295 or mail it to Chassisworks at 8661 Younger Creek Drive, Sacramento, CA 95828.

If you have any additional questions, please contact our Technical Department at (916) 388-0288 for help.

SO#	CUSTOMER	DATE
-----	----------	------

I HAVE PROVIDED THESE SPECIFICATIONS FOR MY A-ARM CROSSMEMBER. I ACCEPT RESPONSIBILITY FOR THEIR ACCURACY. SIGNATURE

TIRE SIZE	WHEEL SIZE	WHEEL SPACING
-----------	------------	---------------

CAR YEAR & MODEL	WHEELBASE (FULL FRAMES ONLY)	CROSSMEMBER WIDTH NEEDED (ROUNDED TO NEAREST 1/8 INCH)
------------------	------------------------------	--

A	B	C	D	E	F
---	---	---	---	---	---

$$(A+B) \times 2 = C$$

$$D - C = E$$

$$E - 27 = F$$

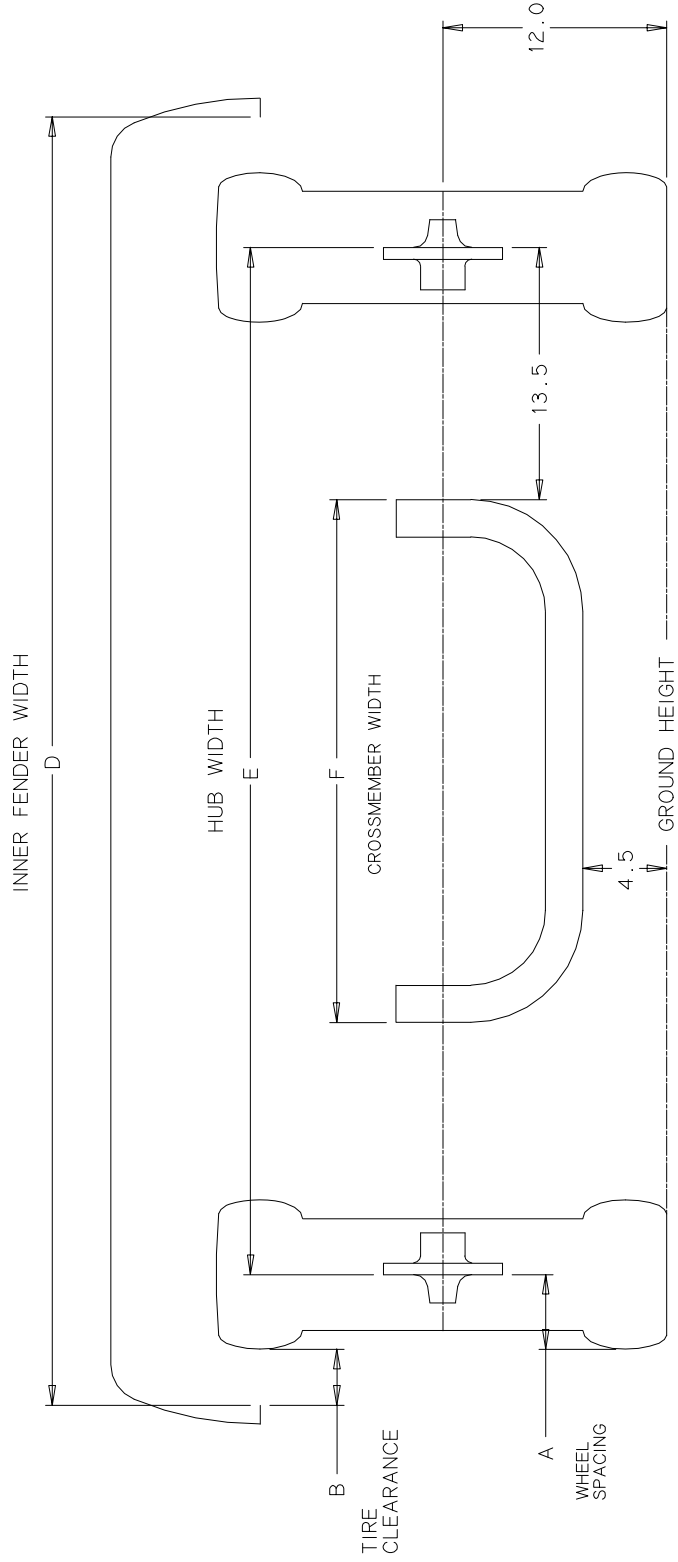

WARRANTY NOTICE:

There are NO WARRANTIES, either expressed or implied. Neither the seller nor manufacturer will be liable for any loss, damage or injury, direct or indirect, arising from the use or inability to determine the appropriate use of any products. Before any attempt at installation, all drawings and/or instruction sheets should be completely reviewed to determine the suitability of the product for its intended use. In this connection, the user assumes all responsibility and risk. We reserve the right to change specification without notice. Further, Chris Alston's Chassisworks, Inc., makes **NO GUARANTEE** in reference to any specific class legality of any component. **ALL PRODUCTS ARE INTENDED FOR RACING AND OFF-ROAD USE AND MAY NOT BE LEGALLY USED ON THE HIGHWAY.** The products offered for sale are true race-car components and, in all cases, require some fabrication skill. **NO PRODUCT OR SERVICE IS DESIGNED OR INTENDED TO PREVENT INJURY OR DEATH.**

Chris Alston's Chassisworks
8661 Younger Creek Drive
Sacramento, CA 95828
Phone: 916-388-0288
Technical Support: tech@cachassisworks.com

