

READ ALL INSTRUCTIONS COMPLETELY AND THOROUGHLY UNDERSTAND THEM BEFORE DOING ANYTHING.
CALL TOTAL CONTROL PRODUCTS TECH SUPPORT (916) 388-0288 IF YOU NEED ASSISTANCE.

INSTALLATION GUIDE



TCP UCA-02-SVH Coil-Spring Upper Control Arms with Straight Pivot Shaft and Offset Tabs 1967-73 Mustang



Description: Adjustable length upper control arm for 4.75" bolt pattern. For use with TCP front coil-over conversion.

Applications: Comet 66-67 & 71-77, Cougar 67-73, Cyclone 66-71, Fairlane 66-71, Falcon 66-70, Maverick 70-77, Montego 68-71, Mustang 67-73, Ranchero 66-71, Torino 68-71

Note: Excludes 70 BOSS 429

IMPORTANT: The outer shock tower reinforcement plate and suspension bump stop must be reinstalled prior to operating the vehicle. Worn or damaged suspension bump stops must be replaced. Failure to provide a proper compression-travel suspension stop will cause unwarrantable damage to the control arm and shock absorber, and possible structural damage to the chassis.

THIS DRAWING CONTAINS PROPRIETARY INFORMATION OF CHRIS ALSTON'S CHASSISWORKS, INC. AND SHALL NOT BE REPRODUCED, TRANSFERRED TO OTHER DOCUMENTS, DISCLOSED TO OTHERS, USED FOR MANUFACTURING, OR FOR ANY OTHER PURPOSE, IN WHOLE OR IN PART WITHOUT PRIOR WRITTEN PERMISSION OF CHRIS ALSTON'S CHASSISWORKS, INC.

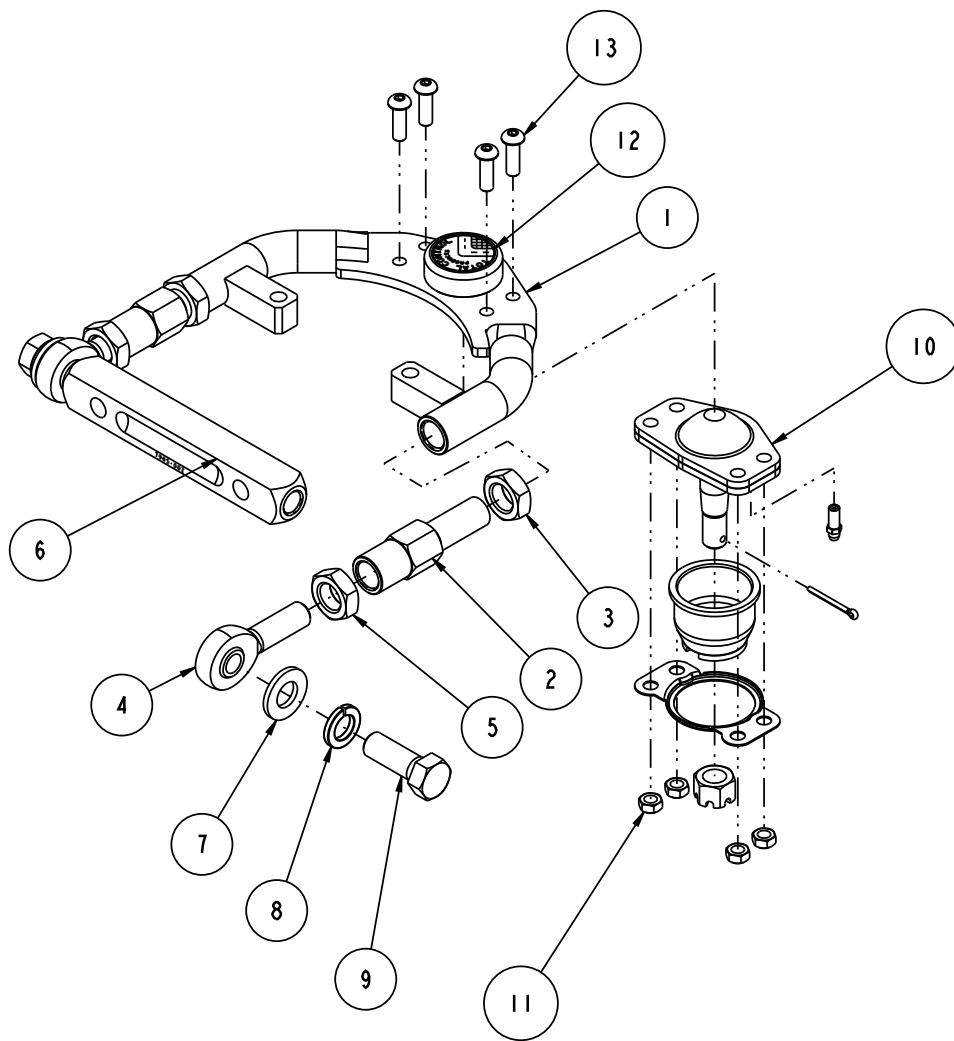

DISCARD SCREW, NUT AND LOCK WASHER INCLUDED WITH BALLJOINT

REVISIONS				
ZONE	REV	DESCRIPTION	DATE	APPROVED
	0	ORIGINAL TCP PART UCA-AS-02	6/21/04	S. RIEGER
	1	NEW REVISION OF SUB-COMPONENTS	10/29/04	S. RIEGER
	2	CHANGE BALLJOINT SCREW AND NUT	10/23/07	S. RIEGER

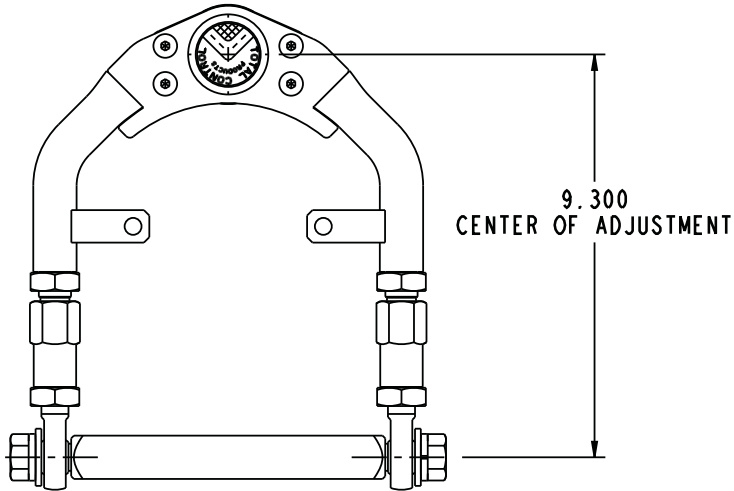

ITEM	QTY	PART NO.	DESCRIPTION
1	1	7905-015	UPPER ARM WELDMENT, TABS, TCP
2	2	7905-003	ADJUSTMENT COUPLER 3/4-16 RIGHT & LEFT
3	2	3102-075-16LY	JAM NUT, 3/4-16 LEFT, YELLOW ZINC
4	2	3112-063X050-L	ROD END, 5/8-18 RIGHT x 1/2 BORE, 4130, NYLON, KMX10-8
5	2	3102-075-16RC	JAM NUT, 3/4-16 RIGHT, CLEAR ZINC
6	1	7905-002	PIVOT SHAFT, 4.75 SPACING, UPPER CONTROL ARM
7	2	3120-063S-Y	FLAT WASHER, 5/8 SAE, HARDENED
8	2	3108-063L-C	LOCK WASHER ϕ 5/8, SPRING
9	2	3100-063FI.75Y	HEX BOLT, 5/8-18 x 1 3/4, GRADE 8, YELLOW ZINC
10	1	7905-023	BALL-JOINT KIT W/HARDWARE 4-BOLT STYLE 1964/1970 MUSTANG
11	4	3129-031-18C	5/16-18 HEX TOP LOCK NUT GRADE C (5) CLEAR ZINC
12	1	7903-DECAL-RI.5	DECAL, ROUND ϕ 1 1/2, TOTAL CONTROL PRODUCTS
13	4	3104-031CI.00C	BUTTON HEAD SOCKET CAP SCREW, 5/16-18 x 1, CLEAR ZINC

UNLESS OTHERWISE SPECIFIED		APPROVALS	DATE	DESCRIPTION	
DIMENSIONS ARE IN INCHES FRACTIONS TOLERANCES $\pm 1/16$ $\pm .5$ $\pm .05$ $\pm .005$		DRAWN BY: S. RIEGER	10/22/04	A-ARM ASSEMBLY, UPPER, WITH TABS, 4.75 MNT SPACING, MUSTANG Chris Alston's CHASSISWORKS INC. 8661 YOUNGER CREEK DRIVE SACRAMENTO, CA 95828 (916) 388-0288 FAX 388-0295	
		CHECKED BY: S. RIEGER	10/23/07		
		DWG RELEASE LEVEL: Released			
FINISH		SIZE		PART NO.	PART REV.
NONE		B		7905-018	2
MATERIAL		SCALE: 1:4		DWG: 7905-018 REV: 2	
ASSEMBLY				SHEET 1 OF 1	

PARTS LIST

TCP UCA-02 - Coil-Spring Upper Control Arms, 4.75" Bolt Pattern

Qty	Part Number	Description
2	7905-018-SVH	UCA assembly 4.75" with offset tabs, straight shaft
2	7905-027	UCA shim .10 x 4.75 spacing
1	7918-021	Hardware bag

7905-018-SVH - Upper Control Arm Assemblies

Qty	Part Number	Description
2	3100-063F1.75Y	Bolt 5/8-18 x 1-3/4" hex head cap screw
2	3102-075-16LY	Jam nut 3/4-16 LH, 1-1/8" hex x .42" tall
2	3102-075-16RC	Jam nut 3/4-16 RH, 1-1/8" hex x .42" tall
4	3104-031C1.00C	Button head 5/16-18 x 1" cap screw
2	3108-063L-C	Lock washer 5/8" regular
2	3112-075X063-R	Rod end RH 3/4"-thread x 5/8"-bore
2	3120-063S-Y	Washer 5/8" flat SAE, hardened
4	3129-031-18C	Top lock nut 5/16-18 all steel
1	7905-002	Pivot shaft, 1/2" holes, 4.75 apart
2	7905-003	Coupler male-female 3/4-16 x 3/4-16 x 3-3/4" length
1	7905-023	Upper balljoint, 4-bolt
1	7905-040-SVH	Upper arm weldment with offset tabs

7918-021 - Hardware Bag

Qty	Part Number	Description
4	3100-038C1.75Y	Bolt 3/8-16 x 1-3/4" hex head cap screw
4	3100-050C2.50Y	Bolt 1/2-13 x 2-1/2" hex head cap screw
4	3101-038-16C	Locknut 3/8-16 nylon insert 9/16" hex x .45" tall
4	3108-050L-C	Lock washer 1/2" regular
4	3110-050-13-8C	Hex nut 1/2-13 Grade 8, yellow zinc plated, 3/4" hex
8	3120-038S-Y	Washer 3/8 flat SAE, hardened
8	3120-050S-Y	Washer 1/2" flat SAE, hardened

INSTRUCTIONS

The photos shown were taken using a 1965 Mustang and may not exactly match your application. However, the installation procedure is the same.

1. Raise front end of car and secure with jack stands. Wheels must not be in contact with the ground.
2. Remove wheels, making note of which side of the vehicle they were removed from.
3. Unbolt the upper shock crossbar from factory shock mount. If installing the TCP coil-over conversion, the factory shock mount must also be unbolted and removed.
4. Unbolt the shock from the coil-spring perch. The nuts are accessed from underneath the control arm.
5. Remove the shock through the top of the shock tower.



- Using a spring compressor, remove the coil spring. Follow the tool manufacturer's instructions for proper use of the spring compressor.



- Remove the cotter pin at the upper balljoint and unscrew the castle nut, **leaving 3-4 threads still engaged.**
- Use a pickle fork to separate the balljoint from the spindle.
- Finish unscrewing the castle nut and remove the spindle.

If the lower control arm is also being replaced, remove spindle from the lower arm following the same procedure.

If you intend on leaving the brake assembly bolted to the spindle, the spindle must be secured to the inner fender using a wire or strap to avoid damaging the brake line.



- Remove upper arm pivot shaft nuts from engine side of shock tower, and remove upper arm.



11. At this time you can drill the shock tower for the dropped position of the UCA using the TCP TOOL-02. Follow the instructions included with the tool.



12. OPTIONAL USE: Mounting shims (7905-027) are only needed to compensate for variances in shock tower alignment. Their purpose is to keep the adjusted length of both control arms relatively close and prevent different suspension geometries at opposite sides of the car. It may be necessary to use both on one side or none for the installation. This determination is made during the alignment process.



13. Place a single 1/2" flat washer over each 1/2" mounting bolt.
14. Raise control arm into its mounting position, insert two bolts through the pivot shaft, and then through the shock tower mounting holes.

Shims are placed between the pivot shaft and shock tower, if needed.



15. Secure the bolts on the engine side of the shock tower using 1/2" flat washers, lock washers, and hex nuts. Torque hardware to 55 lb-ft.



16. Install spring perch onto control arm mounting tabs using the 3/8-16 x 1-3/4" hex bolts, flat washers and locknuts provided. Tighten to 25–35 lb.ft.

17. Place the upper balljoint stud into the spindle upright. Tighten the castle nut to 50 lb-ft., and check the alignment with the cotter pin hole.

18. Tighten the castle nut until the cotter pin can be inserted through the slots and the hole in the ball joint stud. Do not exceed 65 lb-ft.

DO NOT LOOSEN THE CASTLE NUT TO ALIGN THE COTTER PIN.



19. Install the cotter pin and bend the ends in opposite directions around the stud.

20. Check all mounting hardware.

21. Using a spring compressor, reinstall coil spring. Follow tool manufacturer's instructions for proper use of spring compressor.

22. Make sure spring is correctly positioned at upper and lower spring seats.

23. Install shock and upper shock mount. Torque upper and lower mount hardware to 22-34 lb.ft.

24. Balljoints can now be lubricated using standard grease gun.

25. Install wheels to their original position and torque lug nuts.

26. This completes installation.

Alignment

The vehicle must be professionally inspected and aligned prior to regular use.

If a trailer is not available, your alignment will need to be somewhat close to final specs in order to safely drive your vehicle to the alignment shop. Visually determine if the front wheels look straight. They should not appear to “toe” (left to right) -in or -out. The outside of the wheels should be very close to vertical. A few degrees of negative camber (leaning in) is acceptable.

Our recommended alignment specs serve as a starting point for your particular application. Installed components, driver preference, and specific application will have a great affect on the correct settings for your vehicle.

	Street Performance		Road Course		Drag Strip	
	Manual	Power	Manual	Power	Manual	Power
Caster	2-1/2° to 3° pos.	3-1/2° to 4° pos.	2-1/2° to 3° pos	3-1/2° to 4° pos	4° to 6° pos	4° to 6° pos
Camber	0° to 1/2° neg	0° to 1/2° neg	1-1/2° to 2° neg	1-1/2° to 2° neg	0°	0°
Toe (total)	1/16” to 1/8” in	1/16” to 1/8” in	1/16” out to 1/16” in	1/16” out to 1/16” in	1/16” to 1/8” in	1/16” to 1/8” in

Adjusting the Arm

- Loosen jam nuts to allow adjustment of the couplers.
- A thread lubricant is recommended to make adjusting easier and to prevent damage to threads.
- Both Camber and minor Caster adjustments can be made at upper arm.
- Turning adjustment couplers in same direction equal amounts will adjust camber.
- Turning adjustment couplers in opposite direction equal amounts will adjust caster.

Do not turn the adjusters more than two turns different side to side or binding will occur from side loading the rod ends. If you need more caster adjustment, the TCP strut rod can be shortened or lengthen to achieve the same results.

Shortest adjustment length is achieved with the rod end and adjustment coupler threaded completely into their female counterparts.

Center of adjustment is four complete turns of the adjustment coupler from the shortest adjustment length. With the jam nuts threaded to the base of the male threads, there should be four threads visible at each end.

Longest adjustment length is four complete turns of the adjustment coupler from center of adjustment travel. With the jam nuts threaded to the base of the male threads, there should be eight threads visible at each end. If longer adjusted length is needed, use shim/s (7905-026) between pivot shaft and shock tower. *Minimum thread engagement is 3/4”.*

Center of Adjustment Dimensions

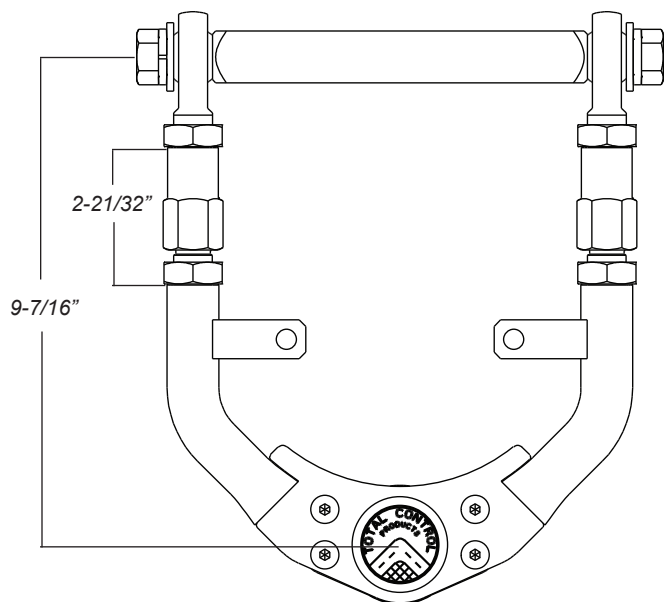

Adjustment range is + or - four threads.

NOTES:

NOTES:

WARRANTY NOTICE:

There are NO WARRANTIES, either expressed or implied. Neither the seller nor manufacturer will be liable for any loss, damage or injury, direct or indirect, arising from the use or inability to determine the appropriate use of any products. Before any attempt at installation, all drawings and/or instruction sheets should be completely reviewed to determine the suitability of the product for its intended use. In this connection, the user assumes all responsibility and risk. We reserve the right to change specification without notice. Further, Chris Alston's Chassisworks, Inc., makes **NO GUARANTEE** in reference to any specific class legality of any component. **ALL PRODUCTS ARE INTENDED FOR RACING AND OFF-ROAD USE AND MAY NOT BE LEGALLY USED ON THE HIGHWAY.** The products offered for sale are true race-car components and, in all cases, require some fabrication skill. **NO PRODUCT OR SERVICE IS DESIGNED OR INTENDED TO PREVENT INJURY OR DEATH.**

Total Control Products
A Chris Alston's Chassisworks, Inc. Brand
8661 Younger Creek Drive
Sacramento, CA 95828
Phone: 916-388-0288
Technical Support: tcptech@cachassisworks.com

