

INSTALLATION GUIDE



TCP ARR1-12

**3/4"-diameter Rear Anti-Roll Bar, Adjustable
1964-73 Mustang**



Description: Adjustable anti-roll bar 3/4" in diameter, includes bolt-on axle mounts, urethane bushings, welded endlink assemblies, and mounting hardware

Applications: Mustang '64-73

PARTS LIST

TCP ARRM1-12

Qty	Description
1	Anti-roll 3/4" rear bar for 1964-73 Mustang

Hardware

Qty	Description
2	Axle U-bolt clamp bracket, 1-7/8 x 5-1/2", 3-3/4" bolt centers
2	Anti-roll-bar bushing clamp, 1-3/8 x 5-3/8", 3-5/8" bolt centers
2	Endlink 5" center-to-center length
2	D-shaped poly bushing, 3/4" ID
4	Endlink bushing, 5/8" OD
2	Poly lube 4cc squirt tube
4	Endlink sleeve, 5/8" OD x 7/16" ID x 1.374" long
8	Locknut 7/16-20
14	Flat washers 1/2" ID .171" thick
2	Flat washers 5/8" ID x 1-3/4" OD
1	Spacer 7/16" ID x 1" OD x 1/4" thick (for brake line tee)
2	Bolt 7/16-20 x 4-1/2" hex head, Grade 8
2	Bolt 7/16-20 x 2-3/4" hex head, Grade 8
2	U-bolt 7/16 x 3-1/4" ID x 4-1/2" tall
2	Sleeve 11/16" OD x 1/2" ID x 1.829" long (for frame)

SAFETY: Before beginning installation, be sure to set the parking brake and chock the wheels.

NOTES: To ease installation and properly adjust the bar, the weight of the vehicle must be on the suspension as if driving down the road. Do not raise the vehicle by the frame.

This kit requires drilling the frame rail and possible relocation of fuel and brake lines. Ensure that the sway bar kit will not interfere with any fuel or brake lines or hoses.

INSTRUCTIONS

1. Lubricate the D-shaped bushings and place them onto the straight areas of the bar at each side of the center hump and as close to the outside bend as possible.
2. Disconnect the hose from axle breather vent.
3. Remove the breather vent bolt from axle.
4. Place the spacer washer underneath the brake line tee and re-attach the vent bolt. (Image 3-1)
5. Reconnect the vent hose.

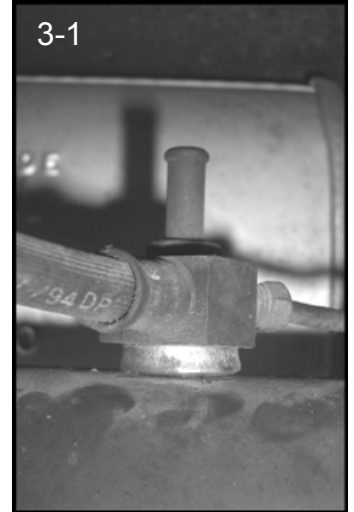

6. Hold the anti-roll bar up to the axle to locate the correct U-bolt positions. Be sure to put the U-bolts under any brake lines, wires, or hoses on the axle to avoid any possible damage. The threads of the U-bolts will point down.
7. Place the saddle brackets onto the U-bolts below the axle tubes.
8. Place the U-plates over the D-shaped bushings on the bar.
9. Secure the anti-roll bar against saddle brackets using the flat washers and nuts provided. **LEAVE LOOSE AT THIS TIME** to allow for adjustment in a later step. (Image 3-2)
10. Position sway bar on axle so that it clears all frame mounted components, including fuel tanks, brake lines, fuel lines, etc. The assembly can be rotated back and forth on the axle to maximize clearance. (Image 3-3)

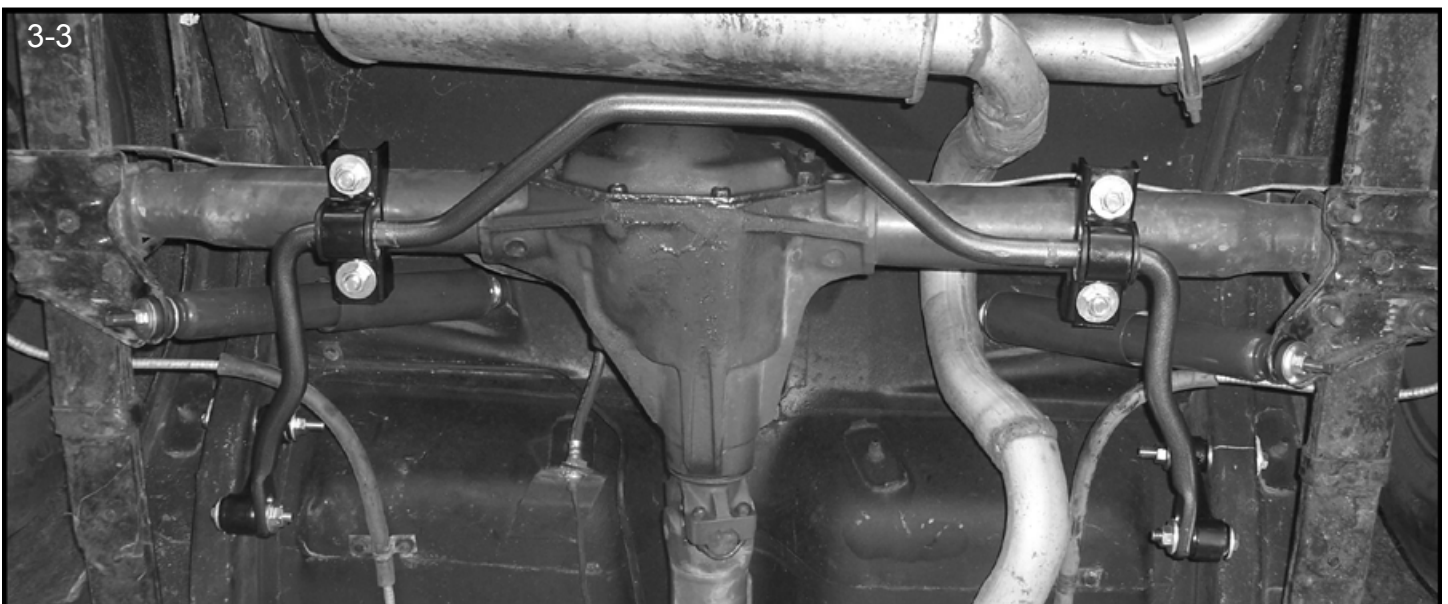
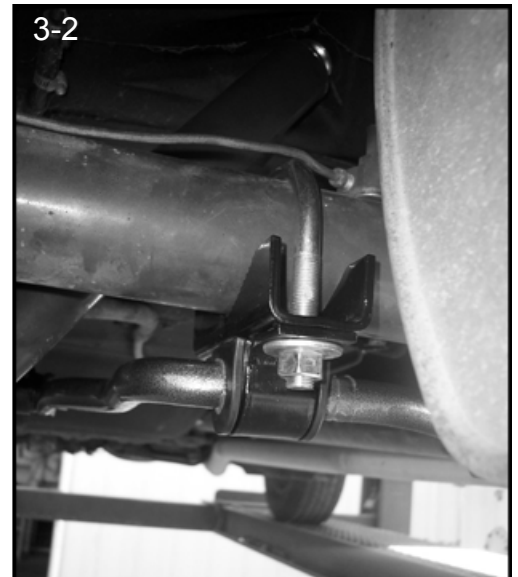

11. Assemble endlinks by inserting the bushings and inner sleeves into the outer sleeves of each endlink. Fully lubricate bushings before installation.
12. Attach endlinks to the outside of the bar arms at the last hole. Use 7/16 x 2-3/4" bolts, flat washers, and locknuts.
13. The endlinks should be located along the frame rail so that the arms of the sway bar are parallel with the ground. (Image 4-1)
14. When satisfied with their position, mark the location of the mounting holes onto the inner frame rail.
15. Prepare to jack up the vehicle by placing wheel chocks on the front wheels. After the rear of the vehicle has been raised, support frame on jack stands and remove rear wheels.



16. The marked hole location must now be transferred to the outside wall of the frame rail.
17. Wrap a small piece of cardboard with a perfectly straight edge around the frame rail as shown. (Image 4-2)
18. Align the cardboard with the center of the hole and score a line across the bottom/back of the frame rail.
19. Mark the hole's center onto the the cardboard with a small line
20. The hole center can be transferred to the outside wall by turning the cardboard 180-degrees and folding over the rail using the same creases in the cardboard and aligning the cardboard with the line scored across the bottom/back of the rail.
21. Mark the location of the hole's center onto the outside rail wall.
22. Review Endlink Mounting Detail illustration on the following page before continuing. (Image 5-2)
- 23. IMPORTANT:** Before drilling any holes in the rail, relocate and protect any fuel or brake lines that may interfere with the drill bit or anti-roll bar installation.



Weld-In Installation

We recommend welding the support sleeve to the frame rail for increased strength. A bolt-in installation method can be use for light-duty/street vehicle use.

24. Drill a 15/32" (.468") hole through BOTH walls of the subframe. Make sure holes are square to one another when drilling. (Image 4-3)



25. Drill an 11/16" (.688") hole through the OUTER wall of subframe ONLY. (Image 5-1)

26. Scotch-brite the area around the 11/16" hole.

27. From the inside of the rail, insert a 7/16 x 4-1/2" bolt through both holes.

28. From the outside of the, insert the 1.720" long spacer sleeve over the bolt and into the hole so that it seats against the inboard wall of the rail.

29. Cleanly TIG weld the sleeve to the outside wall of the frame rail.

30. Paint the area once the weld has cooled.

31. From the outside of the frame rail, insert the 7/16" bolt through the welded sleeve.

32. Place one 1/2" flat washer over the 7/16" mounting bolt, followed by the larger flat washer, and finally the 1.720" long spacer sleeve.

33. From the outside of the frame rail, insert the 7/16" bolt and sleeve through bolt frame rail holes.

34. Place a washer over the bolt, followed by the endlink, a second washer, and the locknut.

35. Torque endlink bolts to 35-40 ft-lb.

36. Replace rear wheels and torque lug nuts to factory specification. Lower vehicle so that the full weight of the vehicle is on the suspension.

37. Tighten axle U-bolts to 35 ft-lb.

Bolt-In Installation

Bolt-in installation method is for use with light-duty/street vehicle use.

38. Drill a 15/32" (.468") hole through BOTH walls of the subframe. Make sure holes are square to one another when drilling. (Image 4-3)

39. Drill an 11/16" (.688") hole through the OUTER wall of subframe ONLY. (Image 5-1)

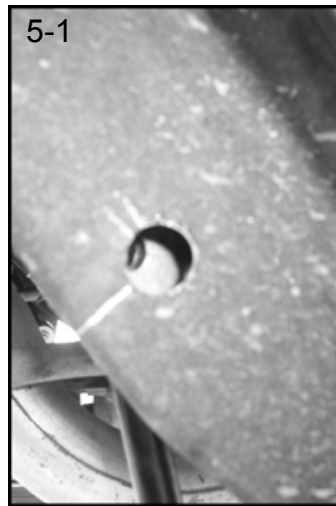

Weld-In Mounting Detail

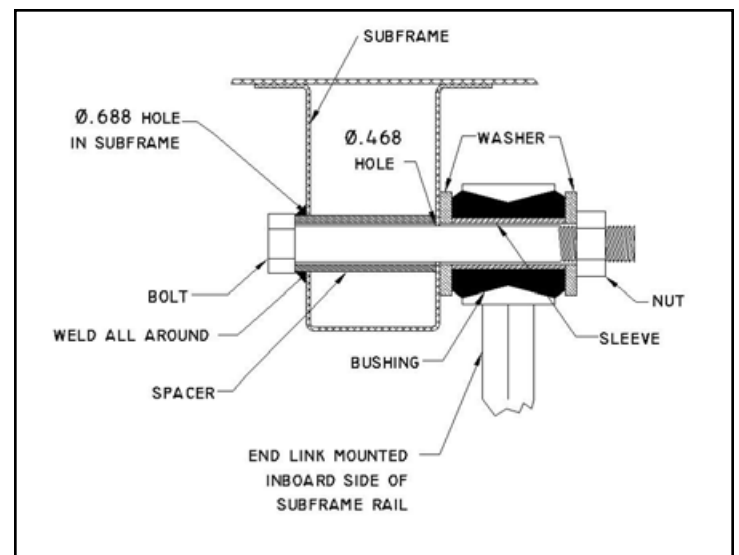

Bolt-In Mounting Detail

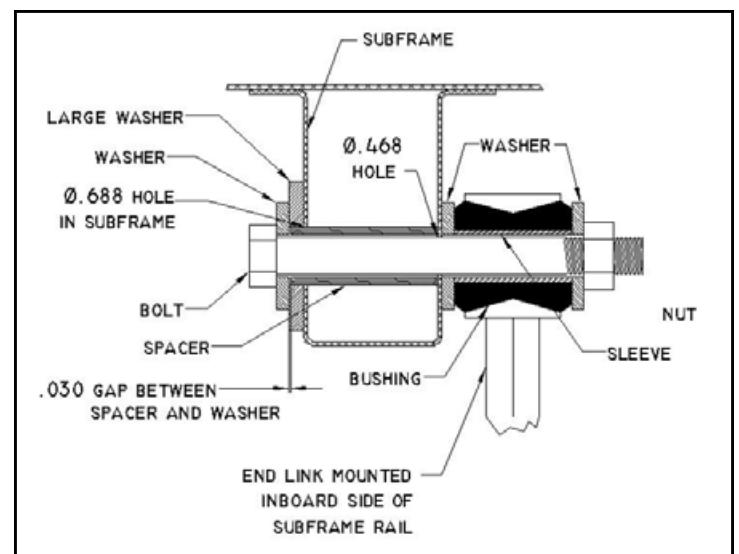

40. Place one 1/2" flat washer over the 7/16" mounting bolt, followed by the larger flat washer, and finally the 1.720" long spacer sleeve.
41. From the outside of the frame rail, insert the 7/16" bolt and sleeve through bolt frame rail holes.
42. Place a washer over the bolt, followed by the endlink, a second washer, and the locknut.
43. Torque endlink bolts to 35-40 ft-lb.
44. Replace rear wheels and torque lug nuts to factory specification. Lower vehicle so that the full weight of the vehicle is on the suspension.
45. Tighten axle U-bolts to 35 ft-lb.

WARRANTY NOTICE:

There are NO WARRANTIES, either expressed or implied. Neither the seller nor manufacturer will be liable for any loss, damage or injury, direct or indirect, arising from the use or inability to determine the appropriate use of any products. Before any attempt at installation, all drawings and/or instruction sheets should be completely reviewed to determine the suitability of the product for its intended use. In this connection, the user assumes all responsibility and risk. We reserve the right to change specification without notice. Further, Chris Alston's Chassisworks, Inc., makes **NO GUARANTEE** in reference to any specific class legality of any component. **ALL PRODUCTS ARE INTENDED FOR RACING AND OFF-ROAD USE AND MAY NOT BE LEGALLY USED ON THE HIGHWAY.** The products offered for sale are true race-car components and, in all cases, require some fabrication skill. **NO PRODUCT OR SERVICE IS DESIGNED OR INTENDED TO PREVENT INJURY OR DEATH.**

Total Control Products
A Chris Alston's Chassisworks, Inc. Brand
8661 Younger Creek Drive
Sacramento, CA 95828
Phone: 916-388-0288
Technical Support: tcptech@cachassisworks.com

