



[CLICK for More Info Online](#)

Upper Control Arm Lowered Pivot Shaft Drill Jig



Our upper control arm drill jigs greatly simplify the process of lowering the control arm mounting position for improved suspension geometry. Jigs are manufactured on our CNC laser cutting machine from 1/4" steel, with guaranteed accuracy unlike commonly used paper templates. The heavy-duty design means the jig can be retained as a shop tool and reused on future projects. Guide holes are full-size and use a 1/2" drill bit to avoid the possibility of 'walking' when drilling out smaller pilot holes.

Features

- Full size guide holes for accuracy
- Single jig is used for both sides of vehicle
- Clearly marked for proper orientation
- Heavy duty steel construction

Benefits to Lower Mounting Position

Lowering the mounting position of the upper control arm to our specifications has two distinct advantages over the stock position; camber gain and roll center height.

Stock Position: Many auto manufacturers design the front suspension of their vehicles to introduce positive camber during hard cornering. As the body rolls and suspension compresses, the top of the wheel is pushed outward, lifting the inside edge of the tire contact patch. The smaller contact area reduces front end traction allowing the front end to push toward the outside of the turn. A vehicle tuned to understeer is less likely to spin-out but at the cost of cornering ability and driver satisfaction.

Lowered Position: The lower mounting position at the shock tower places the upper arm at an inclined angle which draws the top of the wheel inward as the suspension compresses. This is known as negative camber gain and the improved geometry now keeps the tire in better contact with the road. The inclined angle of the upper control arm also moves the roll center of the front suspension upward, closer to the center of gravity of the vehicle. The closer these two points (roll center and center of gravity) are together, the more effective the stabilizer bar and springs are at controlling the vehicles tendency to roll when cornering. Reduced body roll also helps to keep the tire in better contact with the road, increasing traction and greatly improving cornering ability.

Upper Control Arm Drill Jig

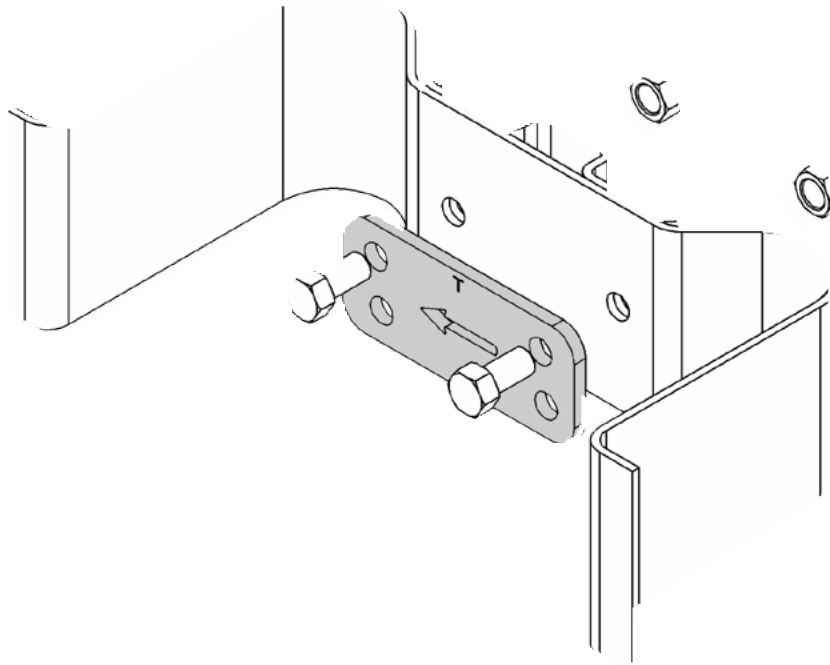

TCP TOOL-01 illustrated

Applications

Make	Model	Year	Part Number
			\$49. ⁰⁰
Ford	Fairlane	1966-1971	TCP TOOL-02
	Falcon	1960-1965	TCP TOOL-01
		1966-1970	TCP TOOL-02
	Mustang	1965-1966	TCP TOOL-01
		1967-1970	TCP TOOL-02
	Ranchero	1960-1965	TCP TOOL-01
		1966-1971	TCP TOOL-02
Torino	1968-1971	TCP TOOL-02	
Mercury	Comet	1960-1965	TCP TOOL-01
		1966-1967	TCP TOOL-02
	Cougar	1967-1970	TCP TOOL-02
	Cyclone	1964-1965	TCP TOOL-01
		1966-1971	TCP TOOL-02
	Montego	1968-1971	TCP TOOL-02

All prices subject to change. Current pricing available at www.cachassisworks.com.



Total Control Products
8661 Younger Creek Drive - Sacramento, CA 95828
A Chris Alston's Chassisworks, Inc. Brand

Order: 800-722-2269
Tech: 916-388-0288
Fax: 916-388-0295

tcpsales@cachassisworks.com
tcptech@cachassisworks.com
www.totalcontrolproducts.com